

**GARBERVILLE SANITARY DISTRICT
BOARD OF DIRECTORS MEETING
AGENDA**

**There will be a regular meeting held by the Garberville Sanitary District Board of Directors at the
GSD District Office
919 Redwood DR. Garberville, CA**

**June 19, 2018
5:00 p.m. – Open Public Session**

Any writings or documents that are public records and are provided to a majority of the governing board regarding an open session item on this agenda will be made available for public inspection in the District Office located at 919 Redwood Dr. during normal business hours.

I. REGULAR MEETING CALLED TO ORDER

II. ESTABLISHMENT OF QUORUM

Rio Anderson___, Linda Brodersen___, Doug Bryan___, Richard Thompson___

III. APPROVAL OF AGENDA - Action to add or delete items from any portion of the agenda or to discuss any consent agenda items must be taken prior to adoption of the agenda.

IV. PUBLIC COMMENT ON ANY ITEM ON THE CLOSED SESSION AGENDA

V. CLOSED SESSION

A. No items for closed session

VI. OPEN SESSION

A. Board Report of action, if any, taken during closed session—No action

VII. COMMENTS AND QUESTIONS FROM THE AUDIENCE

Up to fifteen minutes of this portion of the meeting are reserved for members of the public to address the Board on items not listed on the agenda and within the jurisdiction of the GSD Board. Speakers are limited to 3 minutes. The GSD Board is prohibited by law from taking action on matters discussed that are not on the Agenda, and no adverse conclusions should be drawn if the GSD Board does not respond to public comment at this time.

General Public / Community Groups

VIII. ANNOUNCEMENTS AND COMMUNICATIONS

REPORTS AND PRESENTATIONS – Routine report of activities, operations, meetings / conferences held and/or attended by Board members, Staff, and General Manager

Operations Staff-

Office Staff-

Board Members-

General Manager—Ralph Emerson Pg. 4

Government Code Section 54954.3 provides that the public will have an opportunity to address the Board on any item described on a regular or special meeting either before or during the consideration of that item. The Board reserves the right to limit the time of presentation by individuals and groups

IX. REGULAR AGENDA ITEMS

A. CONSENT AGENDA

Notice to the Public

All matters listed under Consent Agenda are considered to be routine and all will be enacted by one motion and voice vote. There will be no separate discussion of these items unless the Board of Directors requests items to be removed from the Consent Agenda for separate action. Any items will be considered after the motion to approve the Consent Agenda.

- A.1 Approve Financials – pg. 5-17
- A.2 Approve May22, 2018 Regular Meeting Minutes - pg. 18-19
- A.3 Operations Safety Report- pg. 20

Motion: **Second:** **Vote:**

B. GENERAL BUSINESS – Action items

Notice to the Public

The Board of Directors will allow public comment on agenda items although any person who wishes to speak on an agenda item must submit a request prior to the meeting being called to order. You will be given 5 minutes on each agenda item that you wish to comment and then the Board of Directors will discuss the item amongst themselves with no other public comment.

- B.1 Hazardous Work Conditions ---Needles-Dogs-Angry Customers pg. 21
(discussion-possible action)-
Motion: **Second:** **Vote:**

- B.2 Water Treatment Plant Contact Chamber repairs pg. 22-42
(update only)

- B.3 Multi Family-Single Family-Commercial Residence Differences pg. 43
(discussion-possible action)
Motion: **Second:** **Vote:**

- B.4 Rate Study Meeting--Summary pg. 44
(discussion-possible action)

- B.5 Alternative Electricity Planning
(update only)

- B.6 Residential Customer Water Waste pg. 45
(discussion-possible action)

C. POLICY REVISION / ADOPTION

- C.1 Agricultural Water use Ordinance –Section 15.9 pg. 46-52
(discussion possible action) second reading—resolution # 17-013
Motion: **Second:** **Vote:**

- C.2 Payment of Bills Ordinance, Late Charges. Section 9.5 pg. 53
(discussion—no action) first reading (Mary Report)

- C.3 Personnel Policy Introduction—4.2.2 and (Appendix B) Job Descriptions pg. 54-69
(discussion-no action) first reading

X. ITEMS FOR NEXT BOARD MEETING

1. Rate Study
2. 10 year Capital Improvement Plan
3. Agricultural Water Use Ordinance –Sec 15.9
4. Payment of Bills (late charges) Ordinance. Section 9.5 (payment of bills)

XI. ADJOURNMENT

Posting of Notice at the District Office no later than June 15, 2018: Agenda is emailed to the local newspapers and those who have requested an agenda in writing or e-mail.

In accordance with the Americans with Disabilities Act, if you need a special accommodation to participate, please contact the Garberville Sanitary District Office at (707)923-9566 at least 48 hours in advance.

**Garberville Sanitary District
PO Box 211
Garberville, CA. 95542
(707)923-9566**

GENERAL MANAGER REPORT

Date: June 19, 2018

We have been working with the State regarding our wastewater treatment process and permit requirements. Rachel Prat is working with us to update our Waste Discharge Requirements (WDRs). I requested changes to the WDRs, when I realized some of the design engineer's expectations could not and were not being met. Some of the primary operational standards to achieve are Bio Chemical Demand (BOD) and Total Suspended Solids (TSS). With normal pond system treatment processes, you expect BODS and TSS to be in the range of 25-40 but the expectations of the design engineer was 15 for both and we are unable to meet those requirements on a consistent basis because pond systems have no way to make adjustments as with a mechanical plant.

Rachel has been very helpful and has proposed changing the WDRs to actual operating range and standards. I have received the draft copy and this should be adopted by the Regional Water Board on September 6th.

I have been updating our maps of the GSD infrastructure while making repairs as needed and doing a lot of research between existing maps to find accuracy. Staff has been assisting me on this and we will continue until we have a complete map which accurately illustrates our infrastructure.

On Saturday May 26, I was contacted by Bonnie Mullaney at Phillipsville Water District, saying that they had a water shortage and needed assistance. I spent 12 hours helping get water flowing into their tanks with Bonnie and Dan. I feel it was a good faith effort on a weekend to assist a neighboring District and they very much appreciated the help.

I have been working on policy and ordinance updates so that we can complete the update process by end of summer.

Respectfully Submitted:

Ralph Emerson



GARBERVILLE SANITARY DISTRICT

P.O. BOX 211 • GARBERVILLE, CA 95542 • (707) 923-9566

BOARD AGENDA MEMORANDUM

Meeting Date: June 19, 2018
To: Garberville Sanitary District Board of Directors
From: Jennie Short, Consultant Project Manager
Subject: April 2018 Financial Statements

GENERAL OVERVIEW AND FINANCIAL CONSIDERATIONS

The attached Financial Statements are for April 2018. As can be seen on the "Combined Revenue & Expense Report for Board" in the YTD Actual (first 10 months of year) column:

- The total revenue is **\$808,977.77**, which is **\$56,768.77** over budget so far this year
- The total expenses are **\$585,447.50**, which is **\$4,975.50** over budget
- The net income excluding depreciation is **\$223,530.27**, which is **\$51,793.27** over budget (good news)

As can be seen on the "Statement of Cash Flows Report for Board - July through April 2018":

- Net cash **DECREASE** year to date is **\$64,946.97** (Note that \$60,000 is still owed from Humboldt County for Measure Z and has yet to be paid as of 4/30/18 - we have received this payment in May)
- Expenditures for fixed asset acquisition so far this year total **\$160,653.63**
- Total payments on long term debt so far this year total **\$(100,282.84)**. We will still need to make the second semi-annual payment on the water loan, and the monthly payments on the Alderpoint Tank Loan and Copier Lease which total about **\$30,000**.

Payroll related expenses are estimated to exceed the budget by about \$ 18,000. In addition, there have been some unanticipated repairs and equipment purchases which include:

Description	Amount
Redwood Dr/Sprowel Creek Rd Repair	14,612.72
SWTP Backwash Pumps & RW Check Valves	5,451.90
Main Tank Distribution Pumps	10,197.36
Sunnybank Lane Valves	4,026.98
Installation of Manhole & Later on Maple Ln	7,532.00
Measure Z Fire Hydrant Project	10,000
Attorney & CPA fees	14,500
TOTAL	66,320.96

These expenditures will necessitate postponing purchasing the trailer, installing the dual LMI pumps at the SWTP, and telemetry upgrades to Wallen Road, Arthur Road, Alderpoint Road Tanks and the WWTP until a future fiscal year. This will save the District approximately \$33,600 to offset the list above.

Moreover, the \$51,793.27 in excess revenue will more than cover the rest, leaving the District with a positive net cash flow of about \$40,000 so long as the insurance company reimburses the expenses for the replacement of the Chlorine Contact Chamber as they are incurred. If the District has to “front” these expenses beyond 6/30/18 then the financial statement will show a negative cash flow for this year and the reimbursement will show up in next year’s financial statements.

ATTACHMENTS

1. Balance Sheet with Comparison between Current month and Fiscal Year ending June 30, 2017
2. Statement of Cash Flows - Current Month and Fiscal Year to Date
3. Revenue and Expense Report - Combined Report for Water & Sewer containing current month actual, fiscal year to date actual, and annual budget
4. Check Register Report for all checks issued in April 2018

Garberville Sanitary District
Combined Revenue & Expense Report for Board
 April 2018

	April 2018 Actual	YTD Actual	YTD Budget	Total Annual Budget	YTD Actual to Budget Difference	Notes
Ordinary Income/Expense						
Income						
Water Charges						
4100 · Residential	21,024.90	241,671.51	237,394.00	290,000.00	(4,277.51)	Extra water use
4110 · Commercial	16,924.46	190,736.51	177,532.00	215,000.00	(13,204.51)	Extra water use
4150 · Bulk Water Sales	0.00	22,764.00			(22,764.00)	Unplanned Revenue
Total Water Charges	37,949.36	455,172.02	414,926.00	505,000.00	(40,246.02)	
4200 · Sewer Charges	28,866.24	299,952.16	303,761.00	365,000.00	3,808.84	
4300 · Connection Fees	8,000.00	24,000.00	16,000.00	64,000.00	(8,000.00)	
4650 · Late Charges	510.00	5,055.00	4,165.00	5,000.00	(890.00)	
4700 · Other Operating Revenue	745.00	6,751.50	171.00	200.00	(6,580.50)	Reconnection fees
49900 · Uncategorized Income	0.00	135.00			(135.00)	Bid package pmt
Total Income	76,070.60	791,065.68	739,023.00	939,200.00	(52,042.68)	\$46,729 over Budget
Expense						
Administrative and General						
5000 · Advertising	0.00	0.00	291.00	350.00	291.00	
5005 · Bad Debts	465.78	1,428.30	4,582.00	5,500.00	3,153.70	
5010 · Bank Charges					0.00	
5012 · Merchant Account Fees	196.36	1,893.74	1,249.00	1,500.00	(644.74)	More CC pmts
5010 · Bank Charges - Other	0.00	1,166.52	1,124.00	1,350.00	(42.52)	
Total 5010 · Bank Charges	196.36	3,060.26	2,373.00	2,850.00	(687.26)	
5020 · Directors Fees	0.00	2,900.00	1,500.00	1,800.00	(1,400.00)	16/17 paid in 17/18
5030 · Dues and Memberships	0.00	4,360.27	2,668.00	3,200.00	(1,692.27)	CSDA \$1622 -> \$2658 Rotary \$180 Qtly
5035 · Education and Training	722.44	1,377.44	2,832.00	3,400.00	1,454.56	
5036 · Education and Training - B.O.D.	0.00	0.00	250.00	299.00	250.00	
Insurance						
5040 · Liability	1,911.23	19,112.30	17,209.00	20,649.00	(1,903.30)	Comprehensive on autos
5050 · Workers' Comp	699.46	8,711.86	13,000.00	15,600.00	4,288.14	Corrections on Admin wages
5055 · Health						
5055.1 · Employee Portion	(607.62)	(6,380.01)	(5,981.00)	(7,177.00)	399.01	
5055 · Health - Other	3,257.77	28,630.55	29,909.00	35,890.00	1,278.45	Mary 1/2 year; budgeted for full year
Total 5055 · Health	2,650.15	22,250.54	23,928.00	28,713.00	1,677.46	
Total Insurance	5,260.84	50,074.70	54,137.00	64,962.00	4,062.30	

Garberville Sanitary District
Combined Revenue & Expense Report for Board
April 2018

	April 2018 Actual	YTD Actual	YTD Budget	Total Annual Budget	YTD Actual to Budget Difference	Notes
5060 · Licenses, Permits, and Fees	2,005.00	18,639.69	18,500.00	22,200.00	(139.69)	
5065 · Auto	0.00	454.44	3,666.00	4,000.00	3,211.56	
5070 · Miscellaneous	0.00	56.58	84.00	101.00	27.42	
5080 · Office Expense	1,314.78	5,980.89	4,668.00	5,600.00	(1,312.89)	Quickbooks in Here
5085 · Outside Services	591.00	6,463.22	10,282.00	11,344.00	3,818.78	
5090 · Payroll Taxes	1,853.85	20,435.49	24,075.00	28,890.00	3,639.51	
5100 · Postage	80.81	2,004.58	2,164.00	2,596.00	159.42	
5110 · Professional Fees	1,285.00	61,574.73	50,000.00	60,000.00	(11,574.73)	Attorney, CPA transition
5130 · Rents	835.00	9,185.00	8,950.00	10,740.00	(235.00)	
5135 · Retirement	573.76	6,090.05	6,184.00	7,422.00	93.95	
5137 · Supplies	0.00	951.61	2,251.00	2,700.00	1,299.39	
5140 · Telephone	756.66	5,817.72	2,333.00	2,800.00	(3,484.72)	Moved from Utilities
5145 · Tools	0.00	596.33	3,666.00	4,000.00	3,069.67	
5150 · Travel and Meetings	0.00	1,095.51	1,332.00	1,600.00	236.49	
5155 · Utilities	200.40	2,030.41	2,000.00	2,400.00	(30.41)	
5160 · Wages						
5165 · Wages - Overtime	99.01	1,868.86	0.00	0.00	(1,868.86)	
5160 · Wages - Other	8,841.58	101,018.14	103,453.00	124,144.00	2,434.86	
Total 5160 · Wages	8,940.59	102,887.00	103,453.00	124,144.00	566.00	
Total Administrative and General	25,082.27	307,464.22	312,241.00	372,898.00	4,776.78	
Sewage Collection					0.00	
6010 · Fuel	237.20	1,811.90	2,375.00	2,850.00	563.10	
6030 · Repairs and Maintenance	38.37	4,583.01	16,667.00	20,000.00	12,083.99	
6040 · Supplies	9.27	1,887.43	1,334.00	1,600.00	(553.43)	Rock/AC stockpile
6050 · Utilities	295.58	3,435.66	4,084.00	4,900.00	648.34	Telephone
6060 · Wages						
6065 · Wages - Overtime Sewer Collec	0.00	1,041.00	1,666.00	2,000.00	625.00	
6060 · Wages - Other	2,742.29	26,756.57	15,648.00	18,776.00	(11,108.57)	
Total 6060 · Wages	2,742.29	27,797.57	17,314.00	20,776.00	(10,483.57)	
Sewage Collection - Other	0.00	6.26			(6.26)	
Total Sewage Collection	3,322.71	39,521.83	41,774.00	50,126.00	2,252.17	

Garberville Sanitary District
Combined Revenue & Expense Report for Board
April 2018

	April 2018 Actual	YTD Actual	YTD Budget	Total Annual Budget	YTD Actual to Budget Difference	Notes
Sewage Treatment					0.00	
6075 · Fuel	237.19	1,811.89	2,166.00	2,600.00	354.11	
6080 · Monitoring	372.50	2,698.23	6,667.00	8,000.00	3,968.77	
6100 · Repairs and Maintenance	0.00	9,209.78	10,416.00	12,500.00	1,206.22	
6110 · Supplies	(17.02)	4,997.85	6,334.00	7,600.00	1,336.15	
6120 · Utilities	771.22	8,148.56	10,000.00	12,000.00	1,851.44	Telephone
6130 · Wages					0.00	
6135 · Wages - Overtime Sewer Treati	0.00	1,033.50	1,250.00	1,500.00	216.50	
6130 · Wages - Other	2,368.37	23,775.96	26,584.00	31,900.00	2,808.04	
Total 6130 · Wages	2,368.37	24,809.46	27,834.00	33,400.00	3,024.54	
Total Sewage Treatment	3,732.26	51,675.77	63,417.00	76,100.00	11,741.23	
Water Trans and Distribution					0.00	
7075 · Fuel	237.20	1,811.90	2,084.00	2,500.00	272.10	
7090 · Repairs and Maintenance	27.00	21,323.53	12,500.00	15,000.00	(8,823.53)	SCR & Redwood Dr
7100 · Supplies	0.00	2,039.78	3,334.00	4,000.00	1,294.22	
7110 · Utilities	314.58	5,374.99	7,500.00	9,000.00	2,125.01	Telephone
7120 · Wages					0.00	
7125 · Wages - Overtime Water Trans	352.50	4,879.75	3,750.00	4,500.00	(1,129.75)	
7120 · Wages - Other	4,407.73	38,412.54	23,636.00	28,364.00	(14,776.54)	
Total 7120 · Wages	4,760.23	43,292.29	27,386.00	32,864.00	(15,906.29)	
Total Water Trans and Distribution	5,339.01	73,842.49	52,804.00	63,364.00	(21,038.49)	
Water Treatment					0.00	
7020 · Fuel	0.00	1,249.56	2,500.00	3,000.00	1,250.44	
7010 · Monitoring	417.50	5,546.87	4,166.00	5,000.00	(1,380.87)	HACH equip \$2,336.38
7030 · Repairs and Maintenance	571.09	14,620.40	4,166.00	5,000.00	(10,454.40)	2 Valves for SWTP Filer
7040 · Supplies	(17.01)	10,310.35	10,000.00	12,000.00	(310.35)	
7050 · Utilities	2,835.46	31,586.34	33,334.00	40,000.00	1,747.66	Telephone
7060 · Wages					0.00	
7065 · Wages - Overtime Water Treat	491.25	5,607.50	4,167.00	5,000.00	(1,440.50)	CL2 Emergency
7060 · Wages - Other	3,586.60	32,124.51	38,700.00	46,440.00	6,575.49	
Total 7060 · Wages	4,077.85	37,732.01	42,867.00	51,440.00	5,134.99	
Total Water Treatment	7,884.89	101,045.53	97,033.00	116,440.00	(4,012.53)	
Total Expense	45,361.14	573,549.84	567,269.00	678,928.00	(6,280.84)	Over Budget - bad
Net Ordinary Income	30,709.46	217,515.84	171,754.00	260,272.00	(45,761.84)	Over Budget - good

Garberville Sanitary District
Combined Revenue & Expense Report for Board
 April 2018

	April 2018 Actual	YTD Actual	YTD Budget	Total Annual Budget	YTD Actual to Budget Difference	Notes
Other Income/Expense						
Other Income						
Property Tax Revenue						
8010 · Secured	0.00	12,284.19	11,500.00	23,000.00	(784.19)	
8020 · Unsecured	0.00	833.93	750.00	1,500.00	(83.93)	
8025 · Prior Years	0.00	0.00	0.00	25.00	0.00	
8030 · Supplemental - Current	0.00	128.12	75.00	150.00	(53.12)	
8035 · Supplemental - Prior Years	0.00	25.92	25.00	50.00	(0.92)	
Total Property Tax Revenue	0.00	13,272.16	12,350.00	24,725.00	(922.16)	
8053 · Water Capital Grant Income	0.00	0.00	0.00	60,000.00	0.00	
8060 · Interest Income	43.28	4,470.83	836.00	1,000.00	(3,634.83)	Budget Incorrect
8070 · Other Non-Operating Revenue	0.00	10.54			(10.54)	
9030 · Homeowners' Tax Relief	0.00	158.56	0.00	350.00	(158.56)	
Total Other Income	43.28	17,912.09	13,186.00	86,075.00	(4,726.09)	
Other Expense						
9040 · Depreciation	43,543.33	435,433.30	437,500.00	525,000.00	2,066.70	
9050 · Interest Expense	596.36	11,897.66	13,203.00	15,843.00	1,305.34	
Total Other Expense	44,139.69	447,330.96	450,703.00	540,843.00	3,372.04	
Net Other Income	(44,096.41)	(429,418.87)	(437,517.00)	(454,768.00)	(8,098.13)	
Net Income	(13,386.95)	(211,903.03)	(265,763.00)	(194,496.00)	(53,859.97)	More Profit than Budgeted
9040 · Depreciation	43,543.33	435,433.30	437,500.00	525,000.00	(2,066.70)	
Net Income Excluding Depreciation	30,156.38	223,530.27	171,737.00	330,504.00	51,793.27	More Revenue than Budgeted
Total Revenue		808,977.77	752,209.00	1,025,275.00	56,768.77	Over Budget - good
Total Expense		585,447.50	580,472.00	694,771.00	4,975.50	Over Budget - bad
Net Income		223,530.27	171,737.00	330,504.00	51,793.27	Over Budget - good
Payroll - RT		222,087.72	208,021.00	249,624.00	14,066.72	Over Budget - bad
Payroll - OT		14,430.61	10,833.00	13,000.00	3,597.61	Over Budget - bad

Garberville Sanitary District
Balance Sheet Prev Year Comparison

As of March 31, 2018

	Jun 30, 17	April 30, 18	\$ Change June 30-April 30	Notes
ASSETS				
Current Assets				
Checking/Savings				
1005 · Umpqua Checking - Operating	13,489.99	2,789.58	(10,700.41)	
1006 · Umpqua System Reserve - Water	56,039.48	35,959.97	(20,079.51)	
1007 · Umpqua System Reserve - Sewer	80,228.22	28,399.19	(51,829.03)	
1011 · Water Enterprise Fund	46,354.75	46,490.05	135.30	
1030 · County Treasury - Sewer Reserve	373,134.13	388,962.96	15,828.83	1st Inst. Of Prop Taxes
1031 · County Treasury - Water Reserve	238,854.09	240,393.83	1,539.74	
1040 · Petty Cash	39.51	39.51	0.00	
1050 · Cash Drawer	200.00	281.63	81.63	
Total Checking/Savings	808,340.17	743,316.72	(65,023.45)	
Accounts Receivable				
11000 · Accounts Receivable - Other	814.70	215.00	(599.70)	
Total Accounts Receivable	814.70	215.00	(599.70)	
Other Current Assets				
1100 · Accounts Receivable				
1110 · Accts Receivable Over Payments	(1,481.30)	(1,957.08)	(475.78)	
1100 · Accounts Receivable - Other	99,758.38	118,607.98	18,849.60	
Total 1100 · Accounts Receivable	98,277.08	116,650.90	18,373.82	
1120 · A/R - Employee	0.00	0.00	0.00	
1450 · Prepaid Rent	835.00	0.00	(835.00)	
1500 · Prepaid Insurance	2,468.34	4,001.03	1,532.69	
1501 · Prepaid Workers Comp	10,225.31	1,513.45	(8,711.86)	
1502 · Prepaid Expenses	6,590.16	1,098.36	(5,491.80)	
1510 · Prepaid Licenses and Permits	0.00	3,312.06	3,312.06	
1550 · Allowance for Doubtful Accounts	(5,000.00)	(5,000.00)	0.00	
Total Other Current Assets	113,395.89	121,575.80	8,179.91	
Total Current Assets	922,550.76	865,107.52	(57,443.24)	
Fixed Assets				
CIP-Meas-Z-Fire Hydrant Replace	0.00	70,000.00		
CIP-CL2 Contact Chamber Replace	0.00	40,927.11	40,927.11	Emergency Project
CIP - SWTP Coag Project	4,806.26	4,806.26	0.00	
CIP - Leino Ln	585.00	585.00	0.00	
CIP - Bear Canyon Aerial	1,236.10	2,766.06	1,529.96	
WATER				
Land - Water	88,698.62	88,698.62	0.00	
Water Easements & Intangibles	177,397.11	177,397.11	0.00	
Treatment	59,930.27	65,432.17	5,501.90	SWTP BW Pump and RW Check Valve
Distribution	2,696,416.81	2,712,664.17	16,247.36	Main Tank Dist Pumps
Pumps	2,909.87	2,909.87	0.00	
DWTP (Water) 2015	4,968,104.88	4,968,104.88	0.00	
Total WATER	7,993,457.56	8,015,206.82	21,749.26	

Garberville Sanitary District
Balance Sheet Prev Year Comparison

As of March 31, 2018

	Jun 30, 17	April 30, 18	\$ Change June 30-April 30	Notes
Water System	142,474.97	142,474.97	0.00	
SEWER			0.00	
Land - Sewer	129,810.68	129,810.68	0.00	
Collection	2,311,580.70	2,334,001.02	22,420.32	Headworks Flow Maple Manhole/ Lateral
Treatment	507,552.59	507,552.59	0.00	
Pumps	9,881.98	13,908.96	4,026.98	Sunnybank Valve
Sewer Project - 2011	2,792,451.91	2,792,451.91	0.00	
Total SEWER	5,751,277.86	5,777,725.16	26,447.30	
Office Equipment	32,004.40	32,004.40	0.00	
Equipment	158,306.60	158,306.60	0.00	
Vehicles	81,171.66	81,171.66	0.00	
MSR/SOI and Annexation Project	157,367.08	157,367.08	0.00	
Accumulated Depreciation-Water	(1,183,142.26)	(1,470,793.06)	(287,650.80)	
Accumulated Depreciation-Sewer	(1,636,657.06)	(1,784,439.56)	(147,782.50)	
Total Fixed Assets	11,502,888.17	11,228,108.50	(274,779.67)	
TOTAL ASSETS	12,425,438.93	12,093,216.02	(332,222.91)	
LIABILITIES & EQUITY				
Liabilities				
Current Liabilities				
Accounts Payable				
2000 · Accounts Payable	26,541.07	9,773.33	(16,767.74)	Wahlund Paid
Total Accounts Payable	26,541.07	9,773.33	(16,767.74)	
Other Current Liabilities				
20000 · *Accounts Payable	1,227.86	0.00	(1,227.86)	
2205 · Accrued Simple	0.00	(41.46)	(41.46)	
2220 · Accrued State PR Taxes	29.71	0.00	(29.71)	
2225 · Accrued Workers Comp	2,019.62	0.00	(2,019.62)	
2230 · Accrued Vacation	16,720.85	16,720.85	0.00	
2250 · Loans Payable - Current Portion	131,750.84	131,750.84	0.00	
Total Other Current Liabilities	151,748.88	148,430.23	(3,318.65)	
Total Current Liabilities	178,289.95	158,203.56	(20,086.39)	
Long Term Liabilities				
2500 · N/P - SWRCB	168,855.28	146,142.06	(22,713.22)	Full Year Pmt made
2605 · RCAC Loan #6200-GSD-02	177,471.14	136,933.39	(40,537.75)	9 of 12 pmts
2655 · Lease Payable - Copier	2,526.29	1,724.78	(801.51)	9 of 12 pmts
2660 · Lease Payable - Ford Motor Cred	27,338.94	14,099.76	(13,239.18)	Full Year Pmt made
2700 · SRF Loan - Water	1,310,497.46	1,287,506.28	(22,991.18)	1 of 2 pmts made
2900 · Less Current Portion	(131,750.84)	(131,750.84)	0.00	
Total Long Term Liabilities	1,554,938.27	1,454,655.43	(100,282.84)	
Total Liabilities	1,733,228.22	1,612,858.99	(120,369.23)	
Equity				
3000 · Contributed Capital	6,129,491.75	6,129,491.75	0.00	
3100 · Retained Earnings	4,845,044.92	4,562,768.31	(282,276.61)	
Net Income	(282,325.96)	(211,903.03)	70,422.93	
Total Equity	10,692,210.71	10,480,357.03	(211,853.68)	
TOTAL LIABILITIES & EQUITY	12,425,438.93	12,093,216.02	(332,222.91)	

Garberville Sanitary District Statement of Cash Flows Report for Board

July 2017 through March 2018

	Year To Date	April 2018	Notes
OPERATING ACTIVITIES			
Net Income	(211,903.03)	(13,386.95)	Includes Depreciation
Adjustments to reconcile Net Income to net cash provided by operations:			
11000 · Accounts Receivable - Other	599.70		
1100 · Accounts Receivable	(18,849.60)	(34,914.80)	
1110 · Accts Receivable Over Payments	475.78	(3,160.82)	
1450 · Prepaid Rent	835.00		
1500 · Prepaid Insurance	(1,532.69)	1,911.23	
1501 · Prepaid Workers Comp	8,711.86	699.46	
1502 · Prepaid Expenses	5,491.80	549.18	
1510 · Prepaid Licenses and Permits	(3,312.06)	1,635.00	
2000 · Accounts Payable	(16,641.91)	(72,127.06)	Wahlund Paid for Hydrants
20000 · *Accounts Payable	(1,227.86)		
2205 · Accrued Simple	(41.46)		
2220 · Accrued State PR Taxes	(29.71)		
2225 · Accrued Workers Comp	(2,019.62)		
Net cash provided by Operating Activities	(239,443.80)	(118,794.76)	
INVESTING ACTIVITIES			
SEWER:Collection	(22,420.32)		
Accumulated Depreciation-Water	287,650.80	28,765.08	
Accumulated Depreciation-Sewer	147,782.50	14,778.25	
CIP-Meas-Z-Fire Hydrant Replace	(70,000.00)		
CIP-CL2 Contact Chamber Replace	(40,927.11)	(27,634.86)	
CIP - Bear Canyon Aerial	(1,529.96)		
WATER:Treatment	(5,501.90)	(50.00)	
WATER:Distribution	(16,247.36)	(50.00)	
SEWER:Pumps	(4,026.98)		
Net cash provided by Investing Activities	274,779.67	15,808.47	
FINANCING ACTIVITIES			
2500 · N/P - SWRCB	(22,713.22)		
2605 · RCAC Loan #6200-GSD-02	(40,537.75)	(4,130.04)	
2655 · Lease Payable - Copier	(801.51)	(81.92)	
2700 · SRF Loan - Water	(22,991.18)		
2660 · Lease Payable - Ford Motor Cred	(13,239.18)		
Net cash provided by Financing Activities	(100,282.84)	(4,211.96)	
Net cash increase for period	(64,946.97)	(107,198.25)	Negative Cash Flow YTD & Month
Cash at beginning of period	808,263.69	850,514.97	
Cash at end of period	743,316.72	743,316.72	Below the \$700,000 reserve + trust account

Garberville Sanitary District
Check Register Report for Board
 April 2018

Date	Num	Memo	Amount
Brett Manus			
04/10/2018	9297		-120.49
Total Brett Manus			-120.49
101 Netlink			
04/16/2018	9301		-243.00
Total 101 Netlink			-243.00
Blue Star Gas			
04/24/2018	9317		-62.64
Total Blue Star Gas			-62.64
Brian Miller			
04/05/2018	9287		-25.97
Total Brian Miller			-25.97
Capital Bank & Trust			
04/05/2018	EFT	557880519	-720.85
04/05/2018	EFT	025158148	-292.06
04/19/2018	EFT	025158148	-281.70
04/19/2018	EFT	557880519	-697.57
Total Capital Bank & Trust			-1,992.18
Crystal Springs Bottled Water			
04/03/2018	9276		-20.00
Total Crystal Springs Bottled Water			-20.00
CSDA			
04/06/2018	DBT		-525.00
Total CSDA			-525.00
Deluxe For Business			
04/06/2018	DBT		-54.93
Total Deluxe For Business			-54.93
EDD			
04/05/2018	EFT	499-0538-3	-63.55
04/05/2018	EFT	499-0538-3	-562.78
04/19/2018	EFT	499-0538-3	-536.12
04/19/2018	EFT	499-0538-3	-39.29
Total EDD			-1,201.74
Fluentstream Tech			
04/03/2018	9277		-108.13
Total Fluentstream Tech			-108.13
Frontier Communications			
04/16/2018	9302		-63.41
Total Frontier Communications			-63.41
Highland Tank & Manufacturing Co.			
04/09/2018	9296		-24,134.86
Total Highland Tank & Manufacturing Co.			-24,134.86
Humboldt County Clerk's Office			
04/03/2018	9284		-50.00
04/03/2018	9285		-50.00
Total Humboldt County Clerk's Office			-100.00
IRS			

Garberville Sanitary District
Check Register Report for Board
April 2018

Date	Num	Memo	Amount
04/05/2018	EFT	68-0296323	-2,695.70
04/19/2018	EFT	68-0296323	-2,530.32
Total IRS			-5,226.02
Jennie Short			
04/05/2018	9288		-3,455.30
04/18/2018	9306		-2,432.65
Total Jennie Short			-5,887.95
La Fond Jamie			
04/04/2018	9286		-129.37
Total La Fond Jamie			-129.37
Lori Ruiz			
04/19/2018	9314		-200.00
Total Lori Ruiz			-200.00
Mitchell, Brisso, Delaney & Vrieze			
04/16/2018	9303		-935.50
Total Mitchell, Brisso, Delaney & Vrieze			-935.50
NAPA			
04/03/2018	9278		-39.27
04/05/2018	9289		-26.05
Total NAPA			-65.32
North Coast Laboratories Ltd.			
04/03/2018	9279		-555.00
04/19/2018	9315		-395.00
Total North Coast Laboratories Ltd.			-950.00
PG&E			
04/10/2018	9298		-4,288.02
Total PG&E			-4,288.02
Pitney Bowes Purchase Power			
04/16/2018	9304		-80.81
Total Pitney Bowes Purchase Power			-80.81
QuickBooks			
04/12/2018	DBT		-610.00
Total QuickBooks			-610.00
Recology Humboldt County			
04/03/2018	9280		-36.67
04/19/2018	9316		-12.00
Total Recology Humboldt County			-48.67
Redwood Merchant Services			
04/02/2018	9386		-90.27
04/30/2018			-120.94
Total Redwood Merchant Services			-211.21
RENNER			
04/10/2018	DBT		-711.59
Total RENNER			-711.59
Resort at Squaw Creek Lake Tahoe			
04/27/2018			-197.44

Garberville Sanitary District
Check Register Report for Board
April 2018

Date	Num	Memo	Amount
Total Resort at Squaw Creek Lake Tahoe			-197.44
Rural Community Assistance Program			
04/16/2018	DBT		-4,717.81
Total Rural Community Assistance Program			-4,717.81
SDRMA			
04/10/2018	9299		-2,922.30
Total SDRMA			-2,922.30
Sentry III Center			
04/24/2018	9318		-835.00
Total Sentry III Center			-835.00
Staples Credit Plan			
04/19/2018	DBT		-84.01
Total Staples Credit Plan			-84.01
State Water Resources Control Board WWOCP			
04/03/2018	9281		-370.00
Total State Water Resources Control Board WWOCP			-370.00
Streamline			
04/03/2018	9282		-100.00
Total Streamline			-100.00
Umpqua Bank			
04/20/2018	9387	Monthly maintenance analysis fee	-186.88
Total Umpqua Bank			-186.88
US Cellular			
04/03/2018	9283		-251.08
Total US Cellular			-251.08
Wahlund Construction, Inc.			
04/18/2018	9307		-70,000.00
Total Wahlund Construction, Inc.			-70,000.00
Wells Fargo			
04/10/2018	9300		-90.51
Total Wells Fargo			-90.51
Wyatt & Whitchurch, E.A. Inc.			
04/16/2018	9305		-950.00
Total Wyatt & Whitchurch, E.A. Inc.			-950.00
Arreguin, Daniel J			
04/05/2018	9290		-2,072.49
04/19/2018	9308		-1,956.11
Total Arreguin, Daniel J			-4,028.60
Emerson, Ralph K			
04/05/2018	9291		-2,946.20
04/19/2018	9309		-2,946.21
Total Emerson, Ralph K			-5,892.41
LaFond, Jamie L			
04/05/2018	9292		-468.40
04/19/2018	9310		-441.91

1:25 PM

06/13/18

Accrual Basis

Garberville Sanitary District
Check Register Report for Board
April 2018

<u>Date</u>	<u>Num</u>	<u>Memo</u>	<u>Amount</u>
Total LaFond, Jamie L			-910.31
Miller, Brian A			
04/05/2018	9293		-1,620.37
04/19/2018	9311		-1,520.89
Total Miller, Brian A			-3,141.26
Nieto, Mary			
04/05/2018	9294		-891.44
04/19/2018	9312		-823.45
Total Nieto, Mary			-1,714.89
Ruiz, Ricardo			
04/05/2018	9295		-464.88
04/19/2018	9313		-137.03
Total Ruiz, Ricardo			-601.91
TOTAL			-144,991.22

**GARBERVILLE SANITARY DISTRICT
BOARD OF DIRECTORS MEETING
MINUTES**

May 22, 2018

5:00 p.m. – Open Public Session

I. REGULAR MEETING CALLED TO ORDER

@ 5:02 p.m.

II. ESTABLISHMENT OF QUORUM

Rio Anderson-Absent

Linda Brodersen-Present

Doug Bryan

Richard Thompson

III. APPROVAL OF AGENDA

Motion: Richard Thompson

Second: Doug Bryan

Vote: 3-0

IV. PUBLIC COMMENT ON ANY ITEM ON THE CLOSED SESSION AGENDA

V. CLOSED SESSION

A. No items for closed session

VI. OPEN SESSION

VII. COMMENTS AND QUESTIONS FROM THE AUDIENCE

General Public / Community Groups

Correspondence---Ed Voice Letters

VIII. ANNOUNCEMENTS AND COMMUNICATIONS

REPORTS AND PRESENTATIONS

Operations Staff- 0

Office Staff- 0

Board Members- Positive strategic planning meeting.

General Manager—Ralph Emerson

The Chlorine Contact Chamber continues to be built and the site of the old chamber has been excavated with failed pipe being removed. We will update you as progress continues and the causation findings are submitted.

IX. REGULAR AGENDA ITEMS

A. CONSENT AGENDA

A.1 Approve Financials

A.2 Approve 4/24/18 Regular Meeting Minutes

A.3 Operations Safety Report

Motion: Richard Thompson

Second: Doug Bryan

Vote: 3-0

B. **GENERAL BUSINESS** – *Action items*

B.1 Town Square Restroom Status
(update only)

The restroom has been built and will be open to the public soon.

B.2 Final 2018-2019 Budget for approval
(discussion-possible action) presentation Jennie Short

Motion: Richard Thompson Second: Doug Bryan Vote: 3-0

There are some changes to the way that we propose to post expenses. Staff has made several iterations of this budget. See pages 26-34 in agenda packet.

B.3 Strategic Plan Meeting Update
(update only)

The District wants to have extra water storage. The chlorine contact chamber has become the most important project to complete at this time. The District is weighing out priorities around town. Certain projects need to be completed first, where as other projects can wait.

B.4 Ten Year Capital Improvement Planning (CIP)
(discussion-possible action)

Tabled

B.5 Alternative Electricity Research
(update only)

The District needs more information, but would like to keep moving towards alternative electricity.

C. **POLICY REVISION / ADOPTION**

C.1 Mission and Vision Statement

Motion: Doug Bryan Second: Richard Thompson Vote: 3-0

C.2 Personnel Policy: Organization chart--Introduction—Sec 3.1
(discussion—possible action) 2nd Reading

The board made some changes to the personnel policy. We will bring this back for approval at the next meeting.

X. **ITEMS FOR NEXT BOARD MEETING**

1. Rate Study Presentation
2. 10 year Capital Improvement Plan
3. Agricultural Water Use Ordinance –Sec 15.9
4. Policy Update
5. Chlorine Contact Chamber Update

XI. **ADJOURNMENT**



@ 6:16 p.m.

Safety Meetings

Operational Hazards

Date May 30, 2018

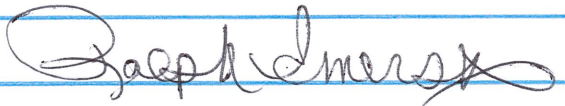
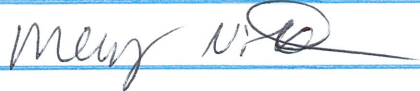
Safety officer - Ralph Emerson

<u>Name</u>	<u>Signature</u>
Ralph Emerson	
Mary Nieto	
Dan Arreguin	
BRIAN MILLER	



Garberville Sanitary District
PO Box 211
919 Redwood Dr.
Garberville, CA. 95542
Office(707)923-9566 Fax(707)923-3130

Hazardous Work Conditions Policy

We have talked about a few of the hazards staff faces as they perform their duties on behalf of the Board, District and customers. I have included a few for discussion because I would like direction and thoughts on a remediation plan to develop policy for addressing the hazards of interaction with community and natural disasters.

1. Dogs biting
2. People angry and threatening
3. Needles in the workplace which includes manholes, meter boxes, ditches and in landscaping
4. Working alone in office
5. Working alone in the field and during storm events
6. Interaction with mentally ill people or transients during course of day
7. Being asked to do favors or work for customers that are not the responsibility of GSD
8. Other Hazards not identified



Garberville Sanitary District
PO Box 211
919 Redwood Dr.
Garberville, CA. 95542
Office(707)923-9566 Fax(707)923-3130

Chlorine Contact Chamber Update

Candorrock Engineering is completing the causation report for SDRMA and has been working with the company building the chlorine contact chamber so we are still optimistic of having the Contact Chamber installed during August.

There is a lot of planning and design work taking place to prepare the site for the contact chamber and Candorrock has been working with staff and the State Water Board to determine what will be required.

I have been in contact with the State Official that will determine the efficiency of the chlorine contact chamber and he is making sure his schedule is open for mid-August, in anticipation of having the chamber installed and ready for operation.

TECHNICAL MEMORANDUM

Investigation of Chlorine Contact Chamber Failure Garberville Sanitary District Surface Water Treatment Plant

Date: June 11, 2018

Prepared For: Ms. Debbie Yokota, Claims Manager, Special District Risk Management Authority

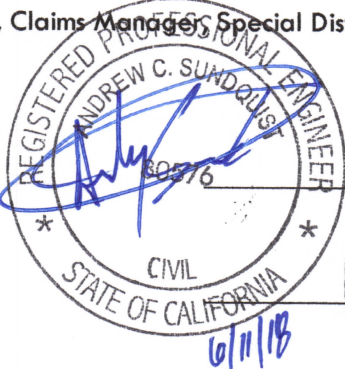
Prepared By: Andy Sundquist, PE 

Prepared By: David Nicoletti, PE 

Attachment 1: Location Map

Attachment 2: GSD Surface Water Treatment Plant Site Plan

Attachment 3: GSD Eel River Pump Station

Attachment 4: CT Chamber Excavation Photos

Attachment 5: Highland Tank Chlorine Contact Chamber

1.0 GSD Surface Water Treatment Plant History

Candor Rock, LLP. (Engineer) has been retained by Special District Risk Management Authority (SDRMA) to investigate the possible cause of Garberville Sanitary District's (GSD) Surface Water Treatment Plant (Plant) Chlorine Contact (CT) Chamber failure that occurred on Thursday, November 23, 2017. The location of the GSD Plant is on APN 222-091-011 on Tooby Ranch Road, south of Sprowl Creek Rd just west of Highway 101 near Garberville, California (Attachment A).

Design and Construction Documents for the GSD Plant were completed by SHN Consulting Engineers and Geologists and advertised for public bid in the spring of 2013. Wahlund Construction was awarded the construction contract in early summer of 2013. The project included construction of a new river intake pump station, transmission main between the new river pump station and treatment Plant, and a new 350 gallon-per-minute surface water treatment plant. Construction activities began in June of 2013, construction activities were completed, and the plant was brought online in September of 2014. Final acceptance of the plant by GSD, was on January 29, 2015.

The GSD Surface Water Treatment Plant has been in operation since late summer 2014 and according to GSD staff there has been operational and performance issues with the Plant since its completion in 2014. Those issues primarily have to do with the Backwash/Recycle pumps, control systems, coagulant injection system, chlorine injection system, and valve actuators on the filter tanks.

In general, the Plant consists of a raw water intake, a polymer injection system, a flocculation tank, two dual media filter tanks, chlorine injection system, underground chlorine contact chamber, and two finish water pumps. To maintain the filter systems, the plant also consists of a filter backwash/recycled water system including two backwash/recycle pumps, a backwash storage tank, and sludge removal system.

At the time of construction, a subsurface chlorine contact chamber (CT Chamber) was built consisting of approximately 285-feet of serpentine 30-inch diameter, DR 41 C905 PVC Big Blue Pipe manufactured by JM Eagle on the south side of the Plant. The CT Chamber also consisted of Star Series 1100 Restraining Glands.

Typical process operation of the Plant begins at the infiltration gallery in the Eel River approximately 2,025-feet north of the Plant, raw river water is pumped through the river pump station to the Plant via 6-inch transmission main. Once the raw water enters the Plant, its routed to a polymer injection station then into the flocculation tank. Raw water exits the flocculation tank and enters the two dual media filters. Water leaving the filters is now considered filtered water and is sent to the chlorine injection station and on to the chlorine contact chamber for disinfection. Finished water is pumped from the chlorine contact chamber into the distribution system and finished water storage tank. Figure 1 represents the process diagram for the existing Plant operation.

Figure 1. Garberville Sanitary District Surface Water Treatment Plant Process Diagram

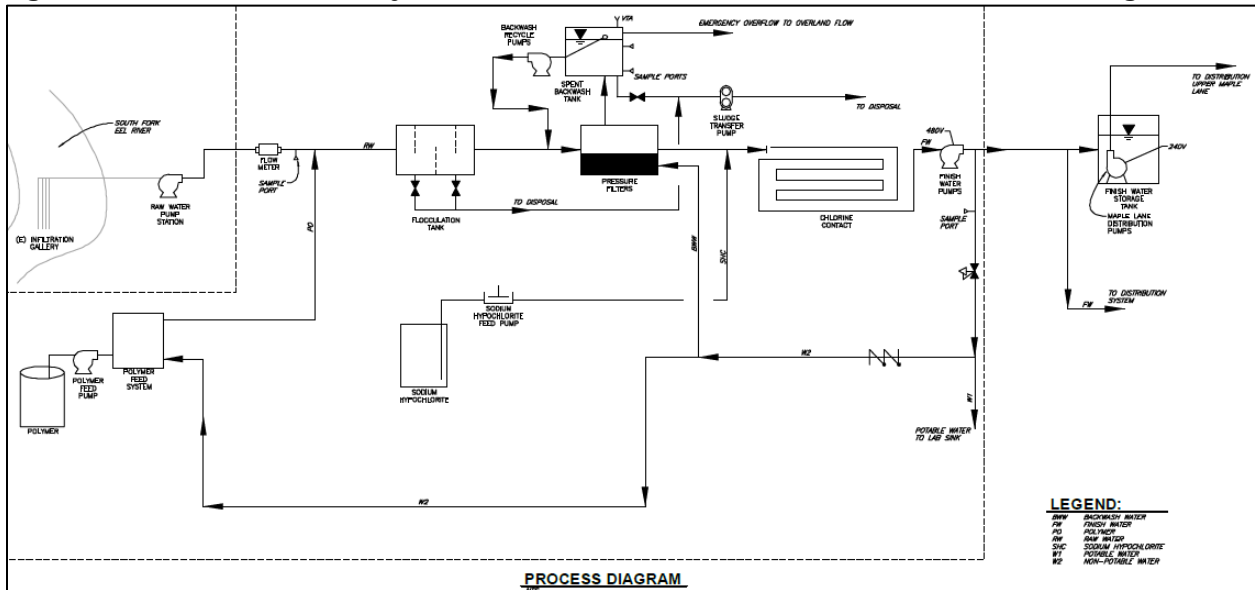

2.0 CT Chamber Failure Event

On Thursday November 23, 2017 (Thanksgiving) at approximately 6:32 PM a catastrophic event at the Plant occurred, specifically a rupture of the underground CT Chamber. Immediately after the rupture of the CT Chamber, water was observed emerging from belowground to the surface in the area of the CT Chamber. The California State Water Resources Control Board, Division of Drinking Water was notified of the CT Chamber failure and subsequently issued a boil water notice to GSD customers. On November 24, 2017, Wahlund Construction was retained by GSD to excavate the ground cover over the CT chamber in the area of the visible surface water. Due to inoperability of the CT Chamber, GSD instructed Wahlund Construction to construct a bypass at the plant directly connecting the filtered water system with the finish water system, omitting the CT Chamber, to continue potable water supply to the community. Candor Rock, LLP. was notified on November 26, 2017 and made an initial site visit on November 27, 2018 for preliminary observations.

Under the emergency conditions, the chlorine residual was increased at the plant and the approximately 5,127-feet of 8-inch main line pipe volume was utilized for temporary chlorine disinfection. Due to the low potable water demand at the time of the failure (winter months) this temporary bypass was accepted by the State and the boil water notice was lifted. Once the potable water demands increase, driving the flow rates up, the main line pipe volume will be insufficient for disinfection unless chlorine residual is increased, which is highly undesirable by GSD customers.

3.0 Methodology:

Based upon the initial observations made November 27, 2018, it was determined that the cracks in the pipe were the cause of hoop stress pressure greater than the pipe walls could maintain to the point of rupture. The following methodology was used to identify the source that caused the rupture:

- Review of the engineering and construction documents that were developed for construction.
- Review of construction inspection reports and material testing results
- Performed site investigations to perform the following:
 - Interview the Plant operators regarding the failure event, the operation of the Plant, and issues arising at the plant since construction.
 - As-Built the internal Plant facility to determine modifications from the original design.
 - Observe the excavation of the failed pipe making up the CT Chamber.
- Contacted the manufacturers of the plant check valves (Flowmatic) and PVC Pipe making up the failed CT Chamber (JM Eagle) to verify operational parameters and capabilities of these appurtenances.

The focus of this investigation is to determine a possible cause of the existing CT Chamber failure.

3.1 Field Observations

Field observations were conducted by Andy Sundquist, P.E. of Candor Rock, LLP. and David Nicoletti, P.E. of DTN Engineering. Site visits were performed on November 27, 2017, May 8, 9, & 11, 2018 for the purposes outlined above.

On May 8, 2018, Wahlund Construction began a full excavation of the failed CT Chamber, results of the excavation and condition of the pipe were documented with photos' (Attachment 3). The excavation on May 8, 2018 was observed by David Nicoletti, initial observations indicated that the PVC C905 pipe exhibited cracks that are indicative of hoop stress failure caused by a pressure burst.

During the site visit by Andy Sundquist, P.E. on Wednesday 9, 2018, Andy observed that two full sections of pipe, connected by two 90° fittings of the CT Chamber had ruptured (Figure 2. Area of Observed Damage to CT Chamber) and the remaining portions of CT Chamber were intact and appeared to be in good condition. As the excavator began removing the portions of ruptured pipe, those sections of pipe crumbled into pieces and could not be removed in whole.

Figure 2. Area of Observed Damage to CT Chamber

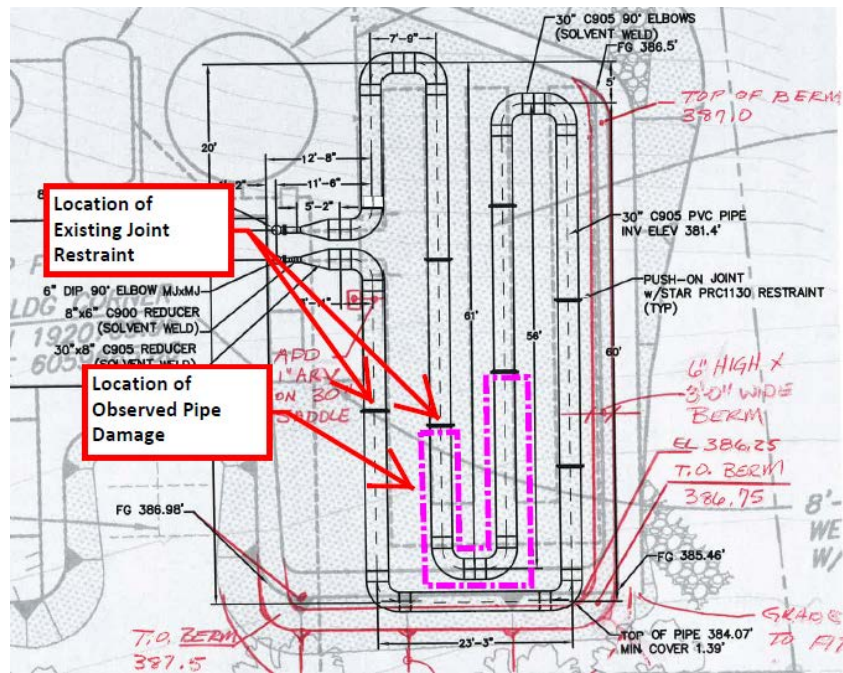

During the excavation, it was observed that the two ruptured sections of pipe and associated 90° fittings, appeared to be discolored or "sun bleached" and the outside wall of the pipe appeared to be "blistering", see figure 3 below.

Figure 3: Discolored and Blistering Pipe



The excavation also uncovered the use of restraining glands that are at the location where the fracture of the PVC pipe appeared to begin.

3.2 Operator Interviews

On May 8, 2018 David Nicoletti PE performed a site visit during the CT Chamber excavation and interviewed Dan Arreguin who is the Plant Operator for GSD. Dan Arreguin stated in the interview that the day preceding the CT Chamber failure, turbidity became difficult to control and on November 23, 2017 it was determined that a backwash of the Plant filters was necessary to control the turbidity levels.

Due to the common failure of the motor operated valve actuators that control the backwash, the backwash procedure is performed manually. In the event of a valve actuator failure, GSD maintains an extensive on-site inventory of replacement valve actuators for installation without delay. In addition to the valve actuator failures, the backwash/recycle pumps are also problematic and blow oil from the oil reservoir during operation. The determination of what caused the high turbidity levels experienced on the 24 hours preceding the CT Chamber rupture was never made, Dan felt it was a possible cracked or broken pipe.

Dan Arreguin and Brian Miller (Assistant Plant Operator) were present at the Plant when the shutdown for backwash occurred. Dan stated that when the Plant shut down occurred, he checked the valve actuator positions at the filter tanks and confirmed they were all in the correct position. Once the plant was shut down, Dan and Brian were in the treatment building ready to start the backwash when they heard a loud noise accompanied with "what sounded like bolts" hitting the side of the metal treatment building. Dan and Brian went outside to investigate the loud noise, and that is when they observed what appeared to be the ruptured CT Chamber.

Upon further discussion Dan outlined a list of issues at the Plant that GSD has either replaced, repaired, or developed a work around from since the Plant was built approximately 5 years ago. Those issues are listed below:

- Automatic motor operated valve actuators don't operate properly and have to be replaced and checked often.
- The backwash/recycle pumps blow oil from the oil reservoir during operation.
- The coagulant system had to be modified in order to use the particular coagulant that GSD uses.
- The VFD controllers required the addition of air conditioners after Plant construction.
- The VFD controllers experienced a failure roughly a year ago.
- The infiltration area for disposal of greywater does not operate properly.

During the site visit on May 8, 2018 Brian Miller demonstrated Plant shutdown for the observation of David Nicoletti P.E. David observed Pump #2 making a loud "cavitation" sound upon startup and operation. The check valve at Pump #2 is no longer "silent" and makes a loud noise upon startup and shutdown. David also observed that there is no surge relief on the finish water pumps, recycle/backwash pumps, or the river pumps. During the observation of identified pressure gauges measuring 30 PSI for the suction

pressure to the finish water pumps and discharge pressure from the finish water pumps of 145 PSI.

4.0 Conclusion:

Based upon the damage observed at the ruptured CT Chamber, an initial assessment of failure was due to a pressure burst caused by “water hammer”. This event caused the CT Chamber to fail by creating an internal pressure greater than the pipe walls could maintain to the point of rupture.

Water hammer occurs when there is a rapid change of fluid velocity. Typical types of events which can change the velocity of the fluid are; pumps turning on and off, and valves being closed rapidly. Water hammer has two effects; one is the change of flow direction, and the other is a creation of a pressure wave that travels at the speed of sound in water, which depending on water conditions, is approximately 4,800±-feet per second. Pressure associated with a pressure wave can increase by hundreds of PSI depending on many factors including the length of travel, the amount of bends in the pipe, and air pockets which may amplify the pressure wave.

4.1 Possible contributing factors:

- Sun blistering is indicative of PVC pipe being exposed to Ultra-Violet (UV) light from being left uncovered in the sun. When PVC pipe gets damaged by UV radiation the pipe turns brittle and loses its flexibility and strength that allows it to accommodate hoop stress. The degradation of the pipe wall may have played a role in the CT Chamber rupture, due to the pieces of pipe that ruptured are the only pieces exhibiting discoloration and sun blistering.
- In addition to the discoloration and sun blistering of the PVC Pipe, the site observations uncovered the use of restraining glands that are at the location where the rupture of the PVC pipe started. This may be a contributing factor to the rupture by not allowing a brittle piece of pipe to move during the water hammer event. The manner in which PVC pipe and other plastic pipe materials handle surge is according to the flexible material characteristics of plastic pipe. In other words when a large pressure associated with a surge is encountered by plastic pipe, the plastic pipe flexes and that flexing dampens the wave to a point that the pipe can handle. According to a white paper developed by JM Eagle and Utah State University titled “The Behavior of PVC Pipe Under the Action of Water Hammer Pressure Waves” states that any restraining of the movement of PVC pipe with joint restraints or compacted fill around the pipe creates rigidity in a material that handles surge by flexing and the rigidity of the pipe increases pressure wave velocity, which is directly tied to pressure increases by higher velocity wave. This physical principle of rigidity and pipe restraint can also be applied to pipe that has turned brittle due to UV exposure.

Upon completion of the investigation for the rupture of the GSD CT Chamber it is our opinion that a pressure wave caused by water hammer created the rupture of the CT Chamber. The source of the pressure wave would need to be identified by computer modeling, which is outside the scope of this investigation, but the cause is likely tied to the Plant shutdown on November 23, 2017. One possible scenario that would explain water hammer and pressure wave, would be the rapid shut down of the finish water pumps, which would create a change of flow velocity. This change of flow velocity could potentially create a significant pressure wave from the discharge side of the finish water pumps, which is also the GSD water distribution system. The finish water pumps have variable frequency drive (VFD) motor controllers that allow slow startup and shutdown of a pump. If a rapid shutdown of a finish water pump occurred the VFD would most likely have malfunctioned, which according to Dan, has happened in the past.

The pressure wave would have to transport through the finish water pumps including the check valves at the pumps to enter the CT Chamber, this could explain the observed noise coming from Pump #2 and the check valve at Pump #2 during startup and shutdown on the site visit of May 8, 2018. On May 10, 2018 David Nicoletti spoke with an Engineer at Flowmatic (check valve manufacturer) regarding the possibility of a pressure wave transporting through the check valve before it could close. The Flowmatic engineer stated that the valve could not close fast enough to stop a pressure wave. The check valve would be able to stop a change of water direction that is associated with water hammer, but due to the velocity of a pressure wave associated with water hammer the check valve could not stop the pressure wave. The Flowmatic engineer also stated that the check valve may have malfunctioned allowing the water to flow backward through the finish water pumps into the CT Chamber. At the conclusion of the investigation it became apparent that there is no surge relief at any of the pumps that were observed.

5.0 Recommend Actions:

It appears that the GSD water system including the river pumps and Plant have been experiencing different levels of surge pressure and water hammer, this is a common phenomenon in all water systems. The GSD water system is of concern because there is very little "surge relief" in the GSD system. The surge relief that exists are above ground water storage tanks and limited use of hydropneumatic tanks throughout the GSD system. Most often the pressure differential created by "water hammer"/surge can be handled by the pipes and appurtenances through their burst ratings, but it does potentially shorten the life of these water facilities and appurtenances. Its our recommendation that both a detailed hydraulic/transient analysis model be developed to evaluate surge and include surge relief devices into the CT Chamebr replacement project. It is also our recommendation that any future pump stations include hydropneumatics tanks and surge relief valves.

The event of November 23, 2017 has caused identifiable damage (CT Chamber), but other components of the system may also be damaged. Pressure testing the discharge

main that proceeds the Plant up Sprowl Creek Rd to verify that no pressure damage occurred to that pipeline during the event failure is recommended. Also, as stated above, the finish water pumps are making loud noise and the backwash/recycle Pumps blow oil out of the oil reservoir and should be inspected by the respective manufacturers of the pumps and replaced if necessary. The check valve at Finish Water Pump #2 should be replaced, and appropriately surge relief valves should be installed on all pumps in the GSD Water System, but specifically at the river pumps, backwash\recycle pumps, and the finish water pumps.

The ruptured CT Chamber is scheduled to be replaced with an above ground pressure vessel (Attachment 4) that will come equipped with appropriate appurtenances to establish sufficient mixing and disinfectant time for the GSD maximum flow rate and water quality characteristics. The tank is an above ground solution to an underground maintenance problem that the ruptured CT Tank had. The above ground CT Tank will also be designed to accommodate seismic forces and since the cause of the pressure wave hasn't been firmly identified, the CT Tank has a working pressure rating of 125 PSI, is factory tested at 187.5 PSI and has an American Society of Mechanical Engineers (ASME) burst rating of 3.5 times the operating pressure or 437.5 PSI. As a redundant protection at the CT Tank for any large surge occurring again, a pressure regulating valve (PRV) will be installed on the CT Tank. This redundancy and the seismic design considerations are appropriate for a critical facility to public health like the GSD Plant and River pumps.

ATTACHMENT 1

Location Map

Location Map

GSD Water Treatment Plant &
GSD River Pumps

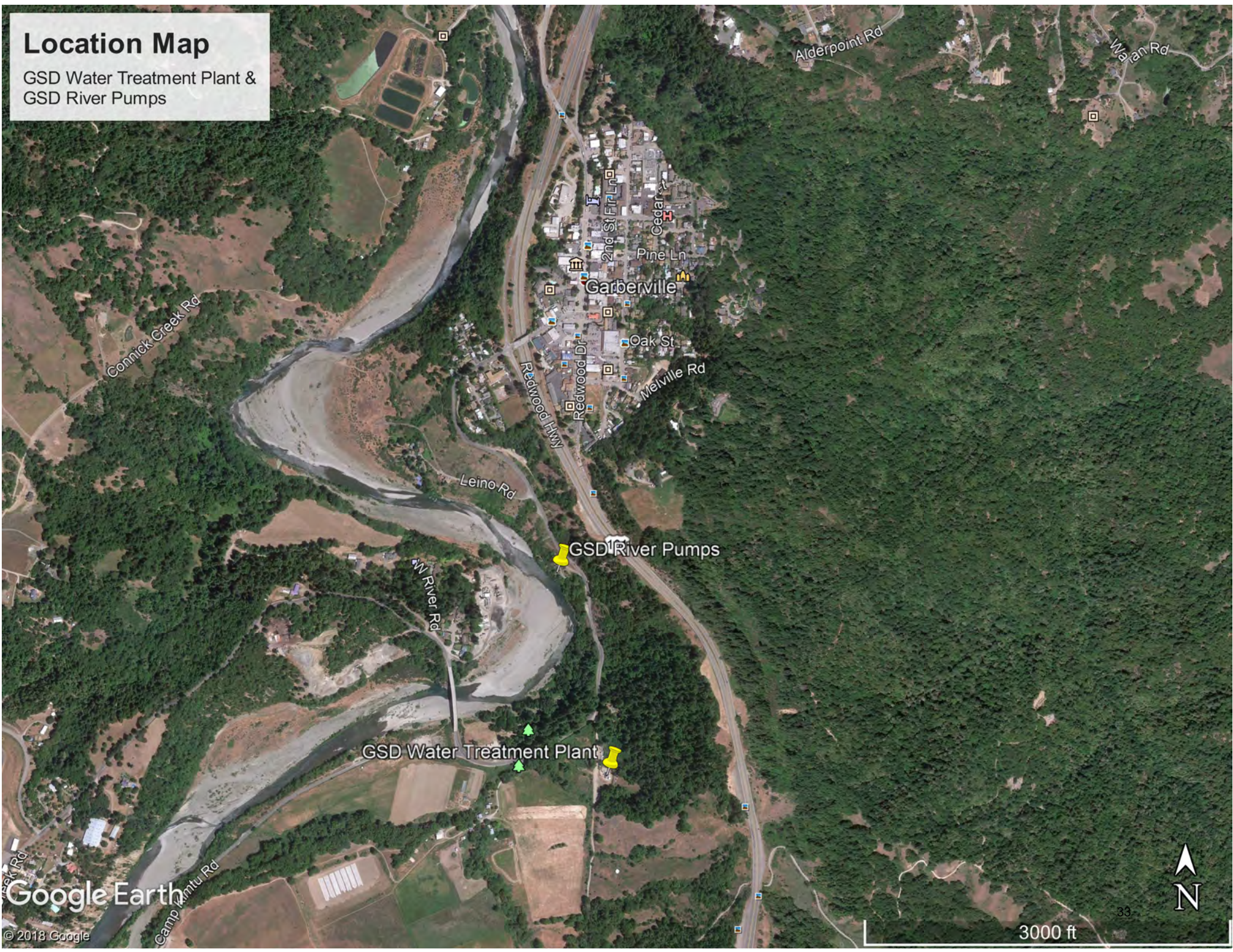

Google Earth

© 2018 Google

3000 ft



33

ATTACHMENT 2

GSD Surface Water Treatment Plant Site Plan

SAVED: 3/1/2013 1:54 PM CNEWELL, PLOTTED: 3/1/2013 1:58 PM CHRIS D. NEWELL
 \\Zing\Projects\2011\011011-GarbervilleSDM\Draws\011011-PLANT-SITE.dwg

NORTHEAST CORNER
 OF EASEMENT
 N 1920998.55
 E 6059814.01

NORTHWEST CORNER
 OF EASEMENT
 N 1921036.87
 E 6059855.63

SURVEY CONTROL		
POINT#	NORTHING	EASTING
BLK#529	1920984.50	6059598.74
BLK#430	1920663.51	6059620.13

SOUTHEAST CORNER
 OF EASEMENT
 N 1920652.44
 E 6059769.34

SOUTHWEST CORNER
 OF EASEMENT
 N 1920651.01
 E 6059624.84

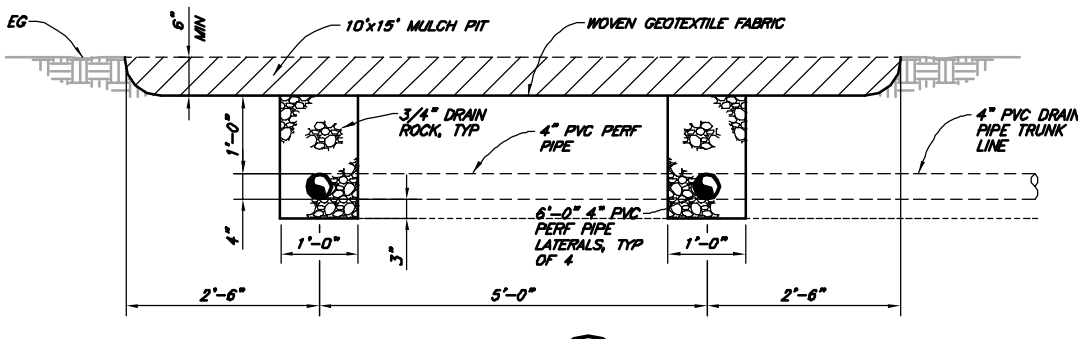
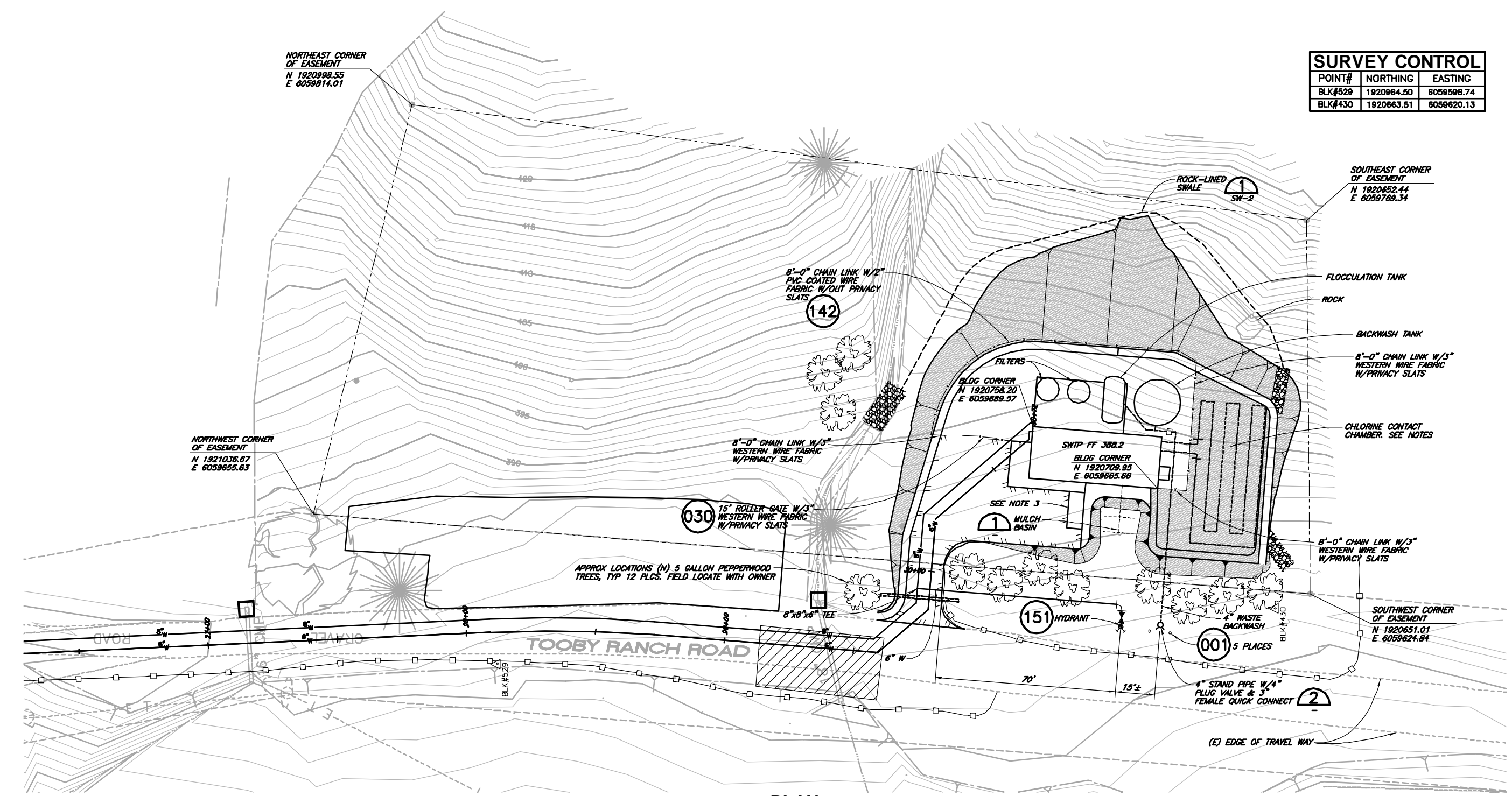

DETAIL 1
 NTS
 SW-1
 SW-4
 SW-6

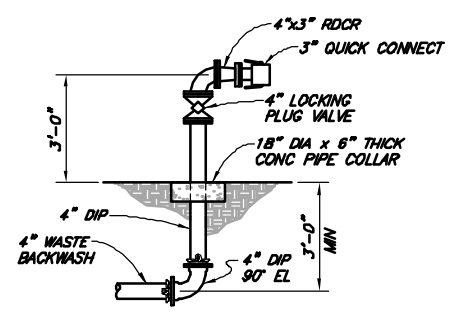

DETAIL 2
 NTS

PLAN
 1\"/>

- NOTES:**
- LOCATION OF PEPPER WOOD TREES TO BE FIELD VERIFIED.
 - CHLORINE CONTACT CHAMBER REQUIREMENTS:
 - 30\"/>
 - 6'x14' GENERATOR PAD. 6\"/>



VERIFY SCALES
 BAR IS ONE INCH ON ORIGINAL DRAWING
 IF NOT ONE INCH ON SCALES ACCORDINGLY

WWW.SHN-ENGR.COM
 812 W. WABASH AVE.
 EUREKA, CA. 95501
 707-441-8855

SHN
 CONSULTING ENGINEERS & GEOLOGISTS, INC.

DESIGN	DR	CHK	APVD	NO.	DATE	REVISION	BY
MCV	CDN	MCV					

GARBERVILLE SANITARY DISTRICT
 DRINKING WATER IMPROVEMENT PROJECT
 GARBERVILLE, CALIFORNIA
SWTP SITE PLAN

DRAWING
SW-1
 SHT 19
 DATE 02/2013
 PROJ. NO. 35 012221
 2/28/2013

ATTACHMENT 3

GSD Eel River Pump Station

SAVED: 2/28/2013 3:45 PM CNEWELL, PLOTTED: 2/28/2013 4:13 PM CHRIS D. NEWELL
 \\Zing\Projects\2011\011011-GarbervilleSDM\Draws\1011011-RAW-WATR-MECH.dwg

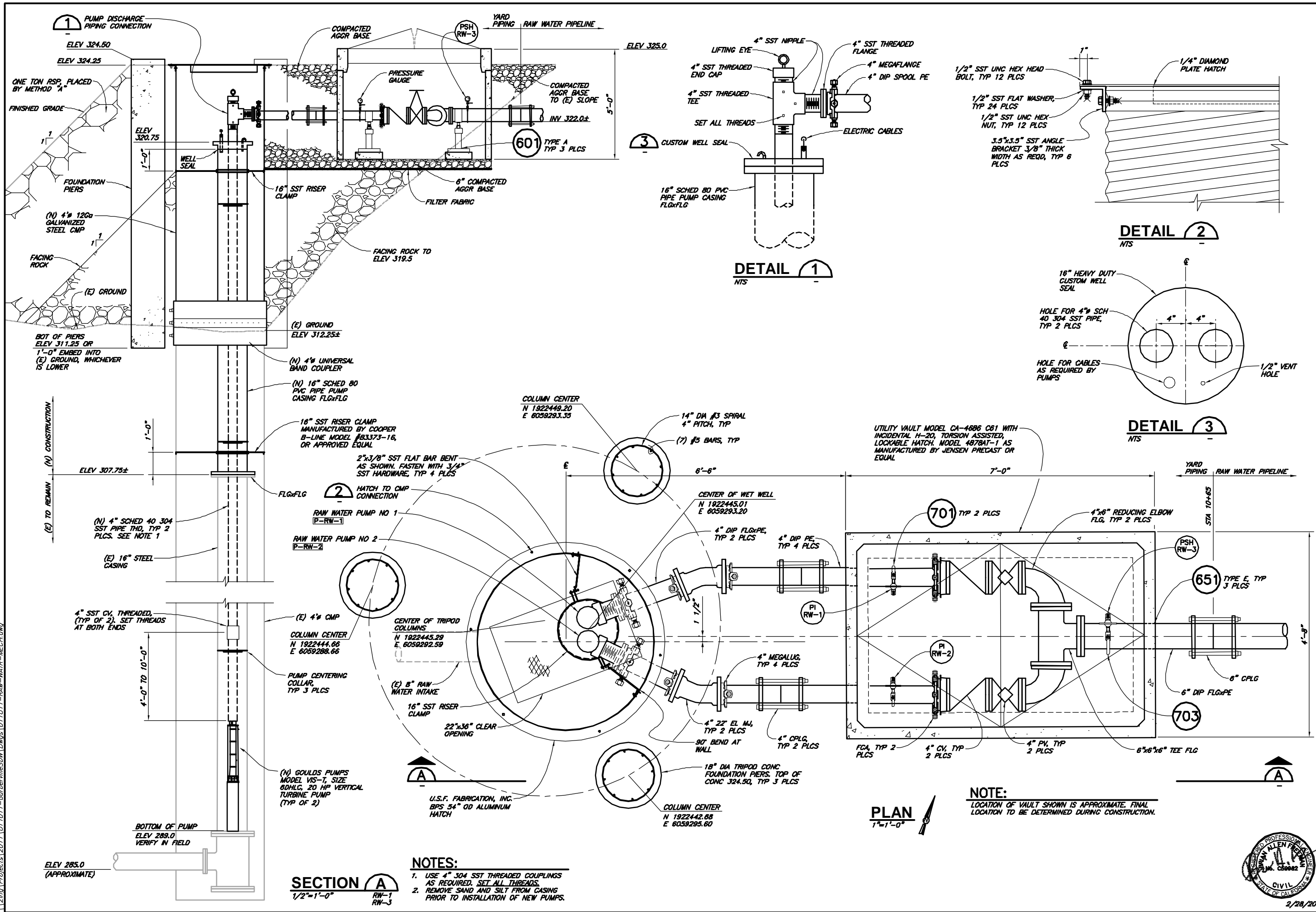

SECTION A
 1/2"=1'-0" RW-1 RW-3

PLAN
 1"=1'-0"

- NOTES:**
1. USE 4" 304 SST THREADED COUPLINGS AS REQUIRED, SET ALL THREADS.
 2. REMOVE SAND AND SILT FROM CASING PRIOR TO INSTALLATION OF NEW PUMPS.

NOTE:
 LOCATION OF VAULT SHOWN IS APPROXIMATE. FINAL LOCATION TO BE DETERMINED DURING CONSTRUCTION.



VERIFY SCALES
 BAR IS ONE INCH ON ORIGINAL DRAWING
 IF NOT ONE INCH ON SCALES ACCORDINGLY

CONSULTING ENGINEERS & GEOLOGISTS, INC.
 WWW.SHN-ENGR.COM
 812 W. WABASH AVE.
 EUREKA, CA. 95501
 707-441-8855

SHN

DESIGN	MD	BY
DR	FV/CDN	REVISION
CHK	MCV	DATE
APPV	ND	NO.

GARBERVILLE SANITARY DISTRICT
 DRINKING WATER IMPROVEMENT PROJECT
 GARBERVILLE, CALIFORNIA

RAW WATER PUMP STATION PLAN AND SECTION

DRAWING **RW-3**
 SHT 17
 DATE 02/2013
 PROJ. NO. 37 012221
 2/28/2013

ATTACHMENT 4

Chlorine Contact Chamber Excavation Photos



Photo #1 New CT Chamber Prior to Backfill During Construction



Photo #2 Excavated CT Chamber after Rupture



Photo #3 CT Chamber Rupture Starting @ Joint Restraint



Photo #4 Close up of Rupture Starting @ Joint restraint



Photo #5 Typical Pattern of Hoop Stress Fracture



Photo #6 Peeling of Sun Bleached Pipe @ Bend Exhibiting Failure

ATTACHMENT 5

Highland Tank Chlorine Contact Chamber

ASME Chlorine Contact Tanks

HT-1121



Highland Tank[®]

Performance Engineered & Custom Fabricated



Chlorine Contact Tanks (CCT) are typically used with chlorine injection equipment in a well water system to help comply with strict drinking water standards. This process vessel is specifically designed to achieve sufficient contact time between the injected chlorine and the water that needs disinfection.

Chlorination is the most common disinfection method for public and private drinking water systems. This disinfection process is necessary to kill disease-causing bacteria in the water. In order to be sure the added chlorine is killing the bacteria, the water must have sufficient contact time with the injected chlorine for proper disinfection.

CCT have an inlet on one end and an outlet on the opposite end. The water flows through a series of internal mixing baffles and perforated high efficiency mixing baffles to lengthen the contact time water has with the injected chlorine before it leaves the vessel.

Highland Tank manufactures two models of CCT. The standard models achieve 50%* efficiency which is considered average contact time for chlorination. The premium models achieve an impressive 70%* efficiency. Both designs ensure full chlorine/water mixing and sufficient contact time.

The high-efficiency models' hydraulic flow characteristics are proven to meet or exceed industry standards by providing an efficient engineered system to meet requirements of the EPA's Surface Water Treatment Rule. Use of these superior CCT results in superior contact time and decreased treatment costs.

Sizing for CCT is related to the flow rate and tank efficiency. The standard 50%* efficiency CCT typically require a larger vessel than the 70%* efficiency models. Highland Tank's CCT are lined with maintenance-free, non-contaminating epoxy or polyurethane lining, approved by NSF as suitable for the storage of potable water.

**These baffling factors were approved by the State of New Jersey. Please confirm with local jurisdiction.*

Unmatched Quality & Service



Superior Performance CCT

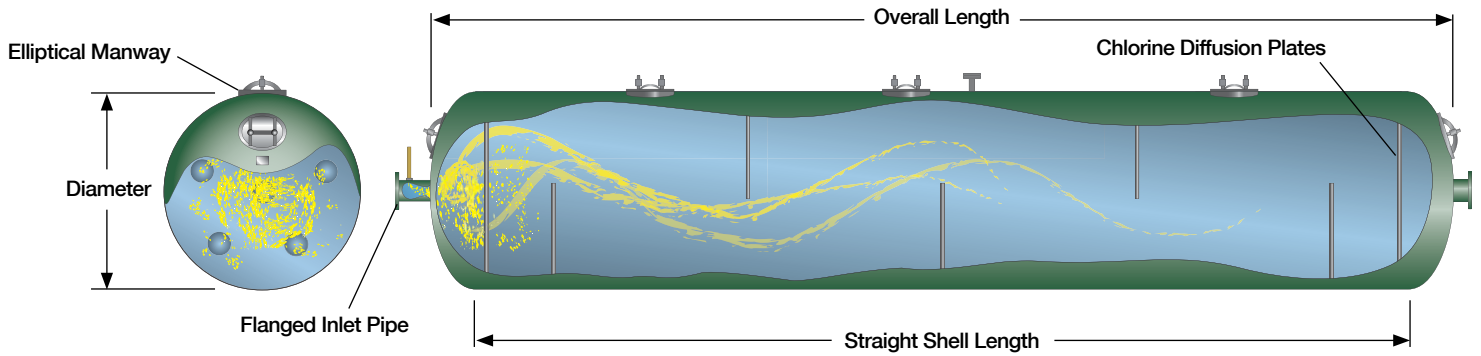

This premium CCT meets a 0.7 baffling factor resulting in superior chlorine contact time. This vessel obtained approval for PA, NJ and NY DEP Bureau of Water Management for Ground Water Rule 4-Log Treatment Demonstration.

Standard Performance CCT

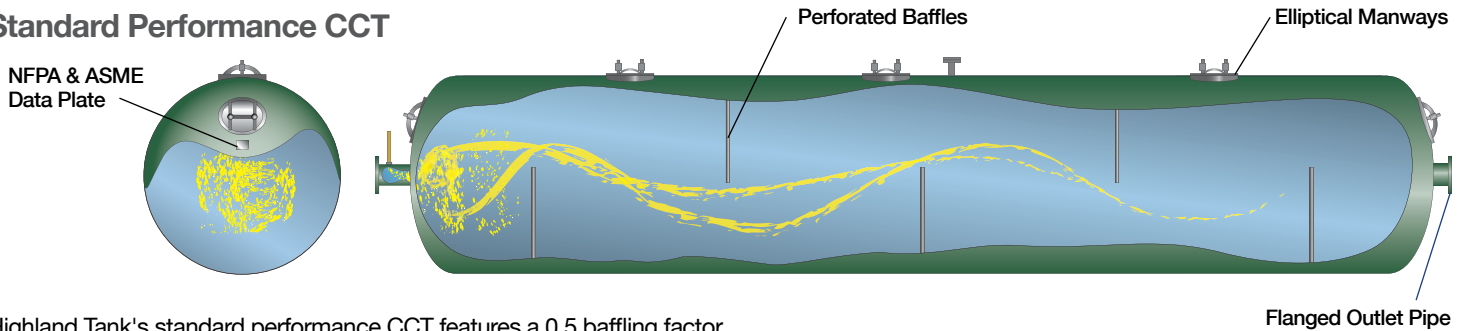

Highland Tank's standard performance CCT features a 0.5 baffling factor. This is a typical design for providing the required contact time for most states and municipalities.

Volume Gallons	Straight Shell Dimensions		Approximate Overall Length	Volume Gallons	Straight Shell Dimensions		Approximate Overall Length
	Diameter	Length			Diameter	Length	
*1,500	4'-0"	15'-6"	17'-9"	7,500	7'-0"	25'-0"	28'-9"
*2,000	4'-0"	21'-0"	23'-3"	7,500	8'-0"	18'-6"	22'-9"
*2,000	4'-6"	16'-0"	18'-6"	8,000	7'-0"	27'-0"	30'-9"
3,000	4'-0"	32'-0"	34'-3"	8,000	8'-0"	20'-0"	24'-3"
3,000	4'-6"	24'-6"	27'-0"	9,000	7'-0"	30'-0"	33'-9"
3,000	5'-0"	20'-0"	22'-9"	9,000	8'-0"	22'-2"	26'-5"
4,000	5'-0"	28'-0"	30'-9"	10,000	8'-0"	25'-0"	29'-3"
4,000	6'-0"	18'-0"	21'-3"	12,000	8'-0"	31'-0"	35'-3"
5,000	6'-0"	24'-0"	27'-3"	15,000	8'-0"	40'-0"	44'-3"
5,000	7'-0"	16'-0"	19'-9"	20,000	10'-0"	32'-0"	37'-3"
6,000	6'-0"	28'-0"	31'-3"	25,000	10'-6"	38'-0"	43'-6"
6,000	7'-0"	20'-0"	23'-9"	30,000	10'-6"	44'-0"	49'-6"
7,000	7'-0"	24'-0"	27'-9"				

Notes: *Only available as Standard .5 performance model CCT.

- Tanks are built in accordance with the latest edition of the ASME Un-fired Pressure Vessel Code. All ASME vessels are welded, tested and inspected per ASME Code requirements and the stamped name plate.
- Thicknesses are calculated per ASME Section VIII, Division I – UG 27.
- Fitting details/locations are determined by application needs.
- Elliptical manways are typically used as inspection openings on chlorine contact tanks.
- Custom sizes and pressures are available upon request. Recommended length should be 3.6 times the diameter of the vessel.
- ASME stamped vessels are required in most states.



Please visit us at www.highlandtank.com

One Highland Road
Stoystown, PA 15563
P: 814-893-5701
F: 814-893-6126

4535 Elizabethtown Road
Manheim, PA 17545
P: 717-664-0600
F: 717-664-0617

958 19th Street
Watervliet, NY 12189
P: 518-273-0801
F: 518-273-1365

2700 Patterson Street
Greensboro, NC 27407
P: 336-218-0801
F: 336-218-1292

2225 Chestnut Street
Lebanon, PA 17042
P: 717-664-0602
F: 717-664-0631

1510 Stoystown Road
Friedens, PA 15541
P: 814-443-6800
F: 814-444-8662



Garberville Sanitary District
PO Box 211
919 Redwood Dr.
Garberville, CA. 95542
Office(707)923-9566 Fax(707)923-3130

WHAT IS DIFFERENCE BETWEEN SINGLE-FAMILY, MULTI-FAMILY OR COMMERCIAL CUSTOMERS

As we update our policies and Ordinances, I continue to come across discrepancies between our existing policies and what is implemented, so I wanted to have a discussion about what constitutes the difference between these categories.

Single-Family Residence: One or more people living in a single home or apartment

Multi-Family Residence: Two or more single-family residences on the same property

Commercial Property: This includes any business that does not have single-family residency on the property or in the building but may have a multi-use property, with single-family units attached or included on the property.

We currently have single-family residences attached to or within commercial businesses that are not separated by individual meters.

We have multiple single-family residences on one residential property but they do not have individual meters or service charges.

Currently we have multi-family residences paying less for water than a single-family residence. The positive yet concerning note is that for some unknown reason we only have one multi-family residence in the system with over 20 residences identified as multi-family.

I started working on identifying multi-family properties but it was not a priority until we developed a new rate structure that addressed all customer occupancy and know that we are close to having a rate proposal for you, I will be putting this issue back on my personal list of tasks to complete.



Garberville Sanitary District
PO Box 211
919 Redwood Dr.
Garberville, CA. 95542
Office(707)923-9566 Fax(707)923-3130

RATE STUDY MEETING

May 29, 2018

Linda, Rich and Mary participated in discussing customer water and sewer rates. The group wants to lower the water rates for low water use customers by including 5 units of water in residential base rate while adjusting rates for high water use customers.

The focus of the group was to have a ten year Capital Improvement Plan and to have the money available to complete those projects while being fiscally responsible with the service charge revenue we receive.

We will be proposing that all rates are rounded off to whole numbers and that there will be a simplified calculation to determine sewer charges. We also want to simplify some of the additional calculations based on meter size and wastewater water strength.

Sewer rates will be calculated by water usage between November and April while commercial customer rates will be calculated during a complete calendar year.

We are close to having a proposal for the Board and public to consider and are optimistic that what is presented will simplify the billing process along with making the service charges easier for staff and the customers to understand.

RESIDENTIAL WATER USE REQUIREMENTS

Staff and I have been working hard to locate and fix leaks while monitoring water diverted, treated, distributed, metered and collected through the wastewater treatment facility and what we have learned is that we have repaired most of the large leaks and are relatively efficient for such an aged infrastructure but there is a concern over residential high water users.

I am presenting this for discussion because although customers pay for their water, they also create a high demand on the aged system and that is a concern.

Many of our customers use treated water for cannabis irrigation on their property but they do not have permits and have not notified us of the reason for their high water demand

There are also customers who have large lawns, gardens and landscape areas which create high water demand so are they to be treated same as commercial agricultural irrigation property?

QUESTIONS

1. Do we want a limit for daily water usage if not in drought conditions or for repairs?
2. Should we investigate high water users to determine if they are using the water for commercial agriculture, including cannabis?
3. If so, do we have jurisdiction to require them to fill out a commercial agricultural application which may include a new connection fee and meter?
4. Do we differentiate between non permitted commercial agriculture irrigation or any other residential irrigation use?
5. Should we look at fines or penalties for not complying with our water use ordinance or using excessive amounts of water? Excessive would be more than 500gpd average or 15,000 monthly.
6. If all residential customers used 500gpd we would treat 150,000 gallons per day just for residential or agricultural use. (301 customers)

AGRICULTURAL—CANNABIS WATER USE ORDINANCE

Possible Ordinance: 15.9 (new ordinance)

1. COMMERCIAL AGRICULTURAL WATER USE REQUIREMENTS

- a. Any person requesting treated potable water for a commercial agricultural business will be required to submit an application at the District office. This application will include the agricultural product, the operational plan, a site map, any permit required by the County and a \$150 handling and inspection fee. This application will be renewed annually or commercial agricultural water use will be denied.
- b. This application will include the name and contact information of the owner and tenant of the property as well as the address of property and estimated gallons of water to be used monthly.
- c. A GSD new and separate approved water meter and connection fee will be required for every approved new commercial agricultural business or farm and all approved applicants will pay an additional base rate and water usage fee.
- d. In the event that Garberville Sanitary District faces drought conditions, infrastructure deficiencies or limitations on the approved diversion rate, the agricultural water will be turned off or limit daily gallons used for irrigation, to ensure adequate water for residential use and human consumption.
- e. All commercial agricultural operations which request water will have their property inspected by the General Manager or designee, at which time the infrastructure will be evaluated to ensure that it is capable of handling the increased water volume.
- f. In the event the infrastructure is not adequate for the increased volume of water, an agreement will be made with the commercial

agricultural business to upgrade the infrastructure or work with the District to do so before the application will be approved.

- g. When an infrastructure upgrade is required but the commercial agricultural business will not pay for or participate in upgrading the infrastructure, the application will be denied.

Any commercial agricultural business will be required to comply with all requirements listed below.

- h. Commercial Agricultural customers will be required to show a water catchment plan that collects water during the winter months while preparing for high demand summer months.
- i. A reconciliation report will be required annually to compare projections with actual water use and efficiency.

i. REASONS FOR DENIED WATER SERVICE

1. Negative impact to neighbors
2. Excessive pedestrian or vehicle traffic based on site visits and complaints.
3. Excessive signage
4. Excessive noise as determined by the District and complaints
5. Excessive lights, glare or brightness

6. Negative smells determined by District and complaints
7. Negative impact to fire suppression capabilities
8. Inadequate water supply
9. Violation of State diversion and permit limits

Noncompliance with any of these requirements or from excessive complaints will result in your application being denied.

RESOLUTION 18-001

THIS RESOLUTION AUTHORIZES THE GARBERVILLE SANITARY DISTRICT TO ADD A NEW AGRICULTURAL WATER USE ORDINANCE SEC. 15.9

A. **WHEREAS,** It has been determined that the Garberville Sanitary District will add a new commercial agricultural Water Use Ordinance, Sec 15.9 to clarify the requirements of the District for a commercial agricultural business using treated water for irrigation.

B. **WHEREAS,** Resolution 18-001 will allow the Board to make appropriate changes to this Ordinance and meet the various water demands of the District.

C. **WHEREAS,** This Resolution will differentiate between residential, commercial and agricultural water use.

D. **WHEREAS,** The adaption of Resolution 18-001 will take effect immediately and will describe the conditions and requirements of using treated water for a commercial agricultural business.

E. **WHEREAS,** The new agricultural water use ordinance Sec 15.9 shall be described below:

AGRICULTURAL—CANNABIS WATER USE ORDINANCE

COMMERCIAL AGRICULTURAL WATER USE ORDINANCE: 15.9

1. COMMERCIAL AGRICULTURAL WATER USE REQUIREMENTS

- a. Any person requesting treated potable water for a commercial agricultural business will be required to submit an application at the District office. This application will include the agricultural product, the operational plan, a site map, any permit required by the County and a \$150 handling and inspection fee. This application will be renewed annually or commercial agricultural water use will be denied.
- b. This application will include the name and contact information of the owner and tenant of the property as well as the address of property and estimated gallons of water to be used monthly.
- c. A GSD new and separate approved water meter and connection fee will be required for every approved new commercial agricultural business or farm and all approved applicants will pay an additional base rate and water usage fee.
- d. In the event that Garberville Sanitary District faces drought conditions, infrastructure deficiencies or limitations on the approved diversion rate, the agricultural water will be turned off, to ensure adequate water for residential use and human consumption.
- e. All commercial agricultural operations which request water will have their property inspected by the General Manager or designee, at which time the infrastructure will be evaluated to ensure that it is capable of handling the increased water volume.
- f. In the event the infrastructure is not adequate for the increased volume of water, an agreement will be made with the commercial agricultural business to upgrade the infrastructure or work with the District to do so before the application will be approved.
- g. When an infrastructure upgrade is required but the commercial agricultural business will not pay for or participate in upgrading the infrastructure, the application will be denied.
Any commercial agricultural business will be required to comply with all requirements listed below.
- h. Commercial Agricultural customers will be required to show a water catchment plan that collects water during the winter months

while preparing for high demand summer months.

- i. A reconciliation report will be required annually to compare projections with actual water use and efficiency

K. REASONS FOR DENIED WATER SERVICE

1. Negative impact to neighbors
2. Excessive pedestrian or vehicle traffic based on site visits and complaints.
3. Excessive signage
4. Excessive noise as determined by the District and complaints
5. Excessive lights, glare or brightness
6. Negative smells determined by District and complaints
7. Negative impact to fire suppression capabilities
8. Inadequate water supply
9. Violation of State diversion and permit limits

Noncompliance with any of these requirements or from excessive complaints will result in your application being denied.

NOW, THEREFORE LET IT BE KNOWN THAT, THE BOARD OF DIRECTORS OF THE GARBERVILLE SANITARY DISTRICT APPROVES THE INCLUSION OF A NEW AGRICULTURAL WATER USE ORDINANCE SEC 15.9

RESOLUTION 18-001 PASSED, APPROVED AND ADOPTED THIS 19TH DAY OF JUNE 2018 BY THE FOLLOWING ROLL CALL VOTE:

AYES:

NOES:

ABSTAIN:

ABSENT:

Linda Broderson, Board President

ATTEST:

Ralph Emerson, General Manager

Sec 9.5 Payment of Bills. Bills are due and payable by 4:30pm on the 25th of each month and if not paid a **\$5** ~~\$10~~-\$25 late charge will be applied.

- (a) Customer Bills:
Bills will be mailed by the first day of each month.
- (b) Late Payment Procedures:
Bills past due—Courtesy call
35 days past due – Shut off notice – Hand delivered to service address
7 days after shut off notice is delivered – Water will be turned off – Owner will be notified.
60 days past due – Lien on building/property – Small claims
120 days past due – Turn over to collection agency
- (c) Adjustment to bills—Payment plans
The General Manager or designee will be the only person authorized to make adjustments to a bill or enter into a payment plan
- (d) NSF (non-sufficient funds) from any payment source will require the customer to Pay all bank charges and a \$35 handling fee.
- (e) Upon 2 NSF (non-sufficient funds) within a 12 month period, automatic payment will be denied until an agreement can be reached with the General Manager or designee.

Approved: 2/27/2018

3.0 EMPLOYMENT PROCESS

3.1 Equal Opportunity

The Garberville Sanitary District will recruit, hire, train, promote and administer human resource activities without regard to age, sex, race, creed, color or national origin, or any other legally protected status, and shall comply with the intent and the letter of all applicable laws which prohibit discrimination and affirm equal opportunity.

3.2 Qualifications

- a. All employees must be at least 18 years of age.
- b. Other qualifications are listed in the job descriptions attached in Appendix “B.”

3.3 Employment Process

All individuals seeking employment with GSD must complete a written application. The **District Administrator General Manager** will conduct an interview of candidates qualified for the position and may give applicant skills tests, which may include but are not limited to: communications, basic math, computer, and job-related licenses, and other qualifications.

The applications of acceptable candidates may be presented to the Board, who may also choose to interview these candidates. The **District Administrator General Manager** will make the final hiring decision. Hiring is contingent upon the new employee’s passing a physical exam and appropriate or necessary drug, background, or other screening deemed necessary by GSD.

3.4 Evaluation Period and Notice of Termination

Following successful completion of a 3-month evaluation period, the employee will be considered a permanent employee. Because GSD is an “at will” employer, notwithstanding that an employee becomes “permanent” in the sense that they have successfully completed their introductory 3-month evaluation period, both GSD and GSD employees have the right to terminate the employment relationship at any time, with a minimum of two weeks written advance notice of the termination date, with or without cause. Notwithstanding this absolute right on the part of GSD or the employee to terminate with or without cause and with or without notice, and without any intention to limit or restrict such rights, both GSD and the employee are encouraged by this policy to provide as much advance notice of termination as reasonable under the circumstances.

4.0 JOB DESCRIPTIONS

4.1 **District Administrator General Manager**

The **District Administrator General Manager** serves as the chief executive officer responsible for supporting the service, financial and capital improvement planning activity of the governing board,

executing actions to cause operations to adjust to enacted policy changes, directing the allocation of responsibility and staffing to departments and managing the scheduling of approved work programs in conformance with applicable statutes, regulations and policies. A complete job description can be found in Appendix B.

4.1.1 Chief Operator

The Chief Operator reports to the **District Administrator General Manager** and is responsible for performing water and wastewater treatment processing and analysis work in conformance with regular procedures, approved treatment processing methods and regulatory prescribed techniques and verifying compliance with requirements and validating quality of completed work. The Chief Operator is responsible for all activities in the operations, maintenance and construction of District facilities. The Chief Operator is also responsible for supervising Operators and Field Staff.

The Chief Operator is directly responsible to notify **both** the **District Administrator General Manager and the Board Chairperson** of any unusual occurrence or emergency situations. **When the General Manager is unavailable the Chief Operator will notify the Board Chairperson. is not available, the Chief Operator will follow the chain of command. A complete job description can be found in Appendix B.**

4.1.2 Operator I 2

The Operator **I 2** reports to the Chief Operator and is responsible for performing water and wastewater treatment processing work in conformance with routine processes, treatment methods and in conformance with regulations and standard work and safety techniques. A complete job description can be found in Appendix B.

4.1.3 Field Staff—Permanent and Part Time

Permanent and temporary part-time field staff report to and are supervised by the

General Manager or Chief Operator and are responsible for completion of all work assigned to them by the **General Manager or** Chief Operator.

4.1.4 Account Clerk/Administrative Assistant/**Secretary**

The Account Clerk/Administrative Assistant/**Secretary** reports to the **District Administrator General Manager** and is responsible for performing accounting and bookkeeping work in conformance with routine processes, accounting and financial transaction processing methods and accounting operations scheduling and control techniques. Responsible for performing a wide variety of general administrative support work and secretarial duties in conformance with established procedures.

A complete job description can be found in Appendix B.

4.2 Workweek

Because of the nature of our business, the District's work schedule may vary depending on the employee's job. The District's normal business hours are 9:00 a.m. to 4:30 p.m., Monday through Friday. The work week begins at 12:01 am on Monday morning and ends at 12:00 midnight on the following Sunday night.

4.2.1 Work Hours

The work week is defined as the 7-day period beginning at 00:01 Monday and ending at 24:00 the following Sunday. The work hours consist of up 30 hours or more between Monday through Sunday in a 7 day period.

The work day is defined as **8 hours worked during a 24 hour period with** the period beginning at midnight and ending at the following midnight.

- a. The **District Administrator General Manager** is intended to be a full time position. This position is exempt from the Fair Labor Standards Act Overtime. The **District Administrator General Manager** will attend all scheduled and special Board meetings.
- b. Part-time office staff will work as scheduled by the **General Manager or designee District Administrator**, with hours not to exceed 8 hours per day or 30 hours per week.
- c. The District office will be open **Monday through Thursday between 9:00am to 5:00pm and closed on Fridays. on a daily schedule to be TBA. The office will be closed between 12:00 to 12:30 for lunch.** Office staff will schedule time so that at least one office staff person will be in the office during business hours.
- d. The Chief Operator and Field Staff will, if necessary, work 40 hours per 7-day workweek, scheduled to avoid overtime.
- e. The Chief Operator will attend all scheduled Board meetings and special Board meetings as required, to be compensated by overtime if over 8 hours per day.
- f. Part-time Field Staff will work as scheduled by the **General Manager** or Chief Operator, with hours not to exceed **30 24** hours per 7-day workweek, **scheduled to avoid overtime. Overtime will not be allowed unless authorized by the General Manager or Chief Operator.**

4.2.2 Meal Time and Breaks

A half-hour, unpaid meal break **should will** be taken each day. Two, 15-minute breaks, one to be taken in the morning and one to be taken in the afternoon **will be taken daily**. These breaks are to be taken based on the employee's work schedule. **The employee is to check with their supervisor if they have questions. Any modifications of meal time or breaks must be approved by the General Manager or designee.**

TITLE: **DISTRICT ADMINISTRATOR**
GENERAL MANAGER

ESSENTIAL FUNCTION

To plan, organize, direct and control the activities and operations of the Garberville Sanitary District consistent with the District's Mission and Vision, to provide the best quality of service and lowest possible cost to the District ratepayers. Works with Board Members and staff to write policy while developing a strategy to implement those policies.

The General Manager is a single position that has full responsibility for the administration of District business while supervising all staff members under the direction of the Board of Directors.

Under policy direction, serves as the chief executive officer responsible for supporting the service, financial and capital improvement planning activity of the governing board, executing actions to cause operations to adjust to enacted policy changes, directing the allocation of responsibility and staffing to departments and managing the scheduling of approved work programs in conformance with applicable statutes, regulations and policies.

PRIMARY DUTIES

Duties may include, but are not limited to, the following:

Act as agent for the Board of Directors in the administration of District business.

Advise the Board on matters of policy and administration; formulate and present to the Board plans to implement policies and accomplish goals established by the Board; and direct implementation of the system of priorities and levels of service established by the Board.

Direct, oversee, and participate in the development of the District's work plan; assign work activities, projects and programs to appropriate department heads; monitor work flow; review and evaluate departments' products, methods and procedures.

Supervise and direct preparation of the annual District budget; direct, review and evaluate annual budget requests of all District departments; and direct the preparation of budget recommendations to the Board of Directors.

Direct continuous review of District expenditures throughout the fiscal year to ensure proper expenditures of authorized funds.

Recommend a long range plan of capital improvements, including provision of pertinent financial data and financing recommendations.

Coordinate District activities with those of outside agencies and organizations; provide staff assistance to the Board of Directors; prepare and present staff reports and other necessary correspondence.

Select, train, motivate and evaluate District personnel; provide or coordinate staff development; work with employees to correct deficiencies; implement discipline and termination procedures.

Represent the District to outside groups and organizations; participate in outside community and professional group committees.

Develop agendas for Board meetings; prepare District reports to the Board of Directors; maintain frequent communications with Board members.

Respond to citizen requests and complaints; research situations and prepare response and action plan for resolution.

Build and maintain positive working relationships with co-workers, other District employees and the public using principles of good customer service.

Perform related duties as assigned by the Board of Directors.

Service Planning: Gather and accumulate information to describe federal, state and regional legislative policy trends in allocating responsibilities, resources, financing and regulation of water and wastewater delivery and processing systems. Direct the development and adoption of long term capital improvement plans, associated services, and financing strategies. Identify industry trends; options and alternatives; recommend long term goals and short term objectives. Direct the development and preparation of budget requests including the description and quantification of service activity and justification of funding requirements for services, personnel, and supplies, routine operating capital equipment and facilities, and special projects.

Service Provided: It is expected that the General Manager be available as needed for all operational and District oversight which may include customer complaints, operational concerns, emergencies or staff disagreements. The General Manager although a salaried position is expected to perform a minimum of 40 hours per week work on behalf of the District unless approved by the Board President or Governing Board.

District Operations: Direct interagency coordination and response to emergency or disastrous events. Establish standards for procedures, systems, equipment, personnel and other means by which operations are conducted. Direct the implementation of policy changes to services, funding levels, position allocations, operating policies, standards, procedures and rules. Coordinate response to claims and litigation in consultation with district counsel and indemnity coverage. Assure that all employment and safety, legal property records, titles and registrations, insurance and permit renewal actions are accomplished in conformance with federal, state, regional laws and regulations and District ordinances, policies and procedures.

District Organization: Recommend the allocation of operating responsibilities to major organizational components. Assign responsibilities and duties to all positions; approve all assignment of internal departmental organization responsibilities and duties to departmental positions. Justify the merits, necessity and organization of responsibility assignments and obtain governing board approval of organization structure. Assure positions are funded and allocated in relation to the approved structure. Initiate employment policy actions to fill all personnel positions. Select and hire all employees. Direct training and formally evaluates employee performance. Take formal commendation, discipline and discharge actions involving personnel.

Work Program Management: Present regular status reports and relevant recommendations on work program status to the governing board. Monitor progress of planning, design and construction of approved capital improvement projects; operating and reporting status of regulatory compliance activities; cash management, budget and service contract performance levels; and status of general operations. Direct the preparation of information and materials for presentation to the governing board, assure compliance with all public agency noticing requirements and applicable policies. Initiate action to cause proper records to be made and follow-up actions from governing board meetings to be accomplished.

Appendix B 1

Garberville Sanitary District

Classification Specifications
Established: 10/03/06

Public and Staff Relations: Respond to inquiries from the public, press, customers, local officials, outside agencies, community organizations, and industry counterparts. Prepare or cause the preparation of analyses, reports, recommendations and position papers on water and wastewater matters pending before legislative or regulatory bodies. Participate in the activities of professional water and wastewater organizations on behalf of the District. Participate in District related committees, civic events and activities of community organizations. Participate in governing board and staff social functions.

Other Assigned Duties: Perform other duties assigned by the governing board which are consistent with the responsibilities of the position and necessary to the operations of the District.

Knowledge of the following is required to perform the essential function:

- Principles, practices, methods and technical support functions of special district services.
- Fundamental intent and basic provisions of federal, state and local financing mechanisms of special district.
- Specific application of federal, state and local legislative enactments applicable to special district utility operations.
- Techniques used for gathering, evaluating and summarizing special district service data and information in preparing budgets and supporting policy decision making processes.
- Personnel and operating practices as they apply to special district operations.

Ability to do the following is required to perform the essential function:

Interpret and apply the general intent and specific provisions of multiple laws and regulations and professional practices to specific issues.
Develop and implement design and construction standards and operating policies and procedures for multiple functional programs and personnel.
Provide verbal and written directives, information and advice to a wide variety of people and officials.
Persuasively communicate ideas and assert a point of view in complex or controversial situations.
Exhibit and instill in subordinates a high public service priority.
Establish and maintain open and honest communications with co-workers at all levels of the organization.

MINIMUM QUALIFICATIONS

Any combination of experience and training that would provide the required knowledge and abilities to govern as General Manager. A typical way to obtain the required knowledge and abilities would be:

EDUCATION: Equivalent Management experience to a Bachelor's degree from an accredited college or university with major course work in public or business administration, political science or a related field.

EXPERIENCE: Ten years of Management experience in a government agency, (preferably with a water/wastewater district) directing, preparing and coordinating a variety of programs including budget and fiscal control; with 3 years' continuous experience as a General Manager.

KNOWLEDGE, SKILLS & ABILITIES:

Knowledge of principles and practices of local government administration, public governance procedures and operations, especially those of a special water/wastewater district as defined in the California Water/Wastewater Code; principles and practices of policy development and implementation; pertinent local, State and Federal laws, rules and regulations; principles and practices of leadership, motivation, team building and conflict resolution; organizational and management practices as applied to the analysis and evaluation of District programs, policies and operational needs; principles and practices of water/wastewater district organization, administration, personnel management, and utility financing; principles and practices of government budget preparation and administration especially characteristic of utility operations.

On a continuous basis, analyze budget and technical reports; interpret and evaluate staff reports; know laws, regulations and codes; observe performance and evaluate staff; problem solve issues related to the operation of District departments; remember various personnel rules; and explain and interpret policy.

The ideal candidate will have current water/wastewater certificates along with experience as a water/wastewater operator and able to do infrastructure repairs and project development.

Qualifying Training and Experience:

A combination of training and experience which demonstrates that a person has obtained the required knowledge and is able to perform the required work.

Employment Conditions:

Specifications Approved by Board of Directors.

Fair Labor Standards Act Overtime:

Exempt.

Appointment and Removal Authority:

Board of Directors.

OPERATIONS MANAGER---SENIOR WATER/WASTEWATER OPERATOR

To direct the District's water operations activities including: 1) managing the operation of the water treatment facilities and chemical/microbiological testing for water quality functions; controlling the water quality aspects of the distribution system up to the customer's tap; conducting applied research, as well as directing and monitoring various water quality programs. Develops related policies and procedures to ensure that all water quality activities are in compliance with applicable laws; regulations; policies, procedures, and quality assurance standards, and; 2) manages the District's water supply function from raw water pumping, storage, conveyance, and treated water pumping, storage and distribution.

The Water/Wastewater Operations Manager is expected to function as liaison with other utilities and regulatory agencies, as well as perform staff assistance in the development of water quality and operations policies and procedures.

Works under the direction of the General Manager.

Duties may include, but are not limited to, the following:

Direct all water operations activities including management of staff and oversight of consultants to ensure that results are accomplished efficiently and in accordance with acceptable standards for quality and technical integrity, and are in compliance with applicable laws, regulations, policies, and procedures under the direction of the General Manager.

Develop, implement, and monitor short- and long- range plans to ensure that the District's water quality standards are maintained cost effectively and efficiently, including implementation of emergency notification procedures to health departments and the public.

Develop policies, set standards and procedures, and administer activities related to the control of water quality, sanitary conditions, and drinking water sources protection to ensure compliance with State and Federal regulatory agencies under the direction of the General Manager.

Direct the District's applied research and testing programs relating to the improvement of water quality and treatment;

Direct the preparation of water quality reports to insure California Water Board compliance, water operations reports and make presentations to the General Manager and Board of Directors, as required, to keep them apprised of water quality and operations activities.

Manage the operation of the water operations function which includes the water distribution system operations, water/wastewater treatment filtration plants, field testing and customer response.

MINIMUM QUALIFICATIONS:

Any combination of experience and training that would provide the required knowledge and abilities is qualifying. A typical way to obtain the required knowledge and abilities would be:

EDUCATION--EXPERIENCE: Minimum of 5 years as a water/wastewater operator with 3 years of management experience or related Equivalent to a Bachelor's degree from an accredited college or university with major course work in water/wastewater science or engineering.

KNOWLEDGE, SKILLS & ABILITIES:

Knowledge of principles and practices of water/wastewater systems operations, including hydraulics of open channel and closed pressurized water systems; modern water treatment regulations, processes, and procedures in a complex water treatment system; automated process control systems (SCADA i.e. supervisory control and data acquisition); pertinent local, State, and Federal laws, rules and regulations relevant to water quality standards, treatment and analyses; budgeting procedures and techniques; principles and practices of supervision, training and personnel management; principles and practices of policy development and implementation; effective communication and presentation techniques and methods.

Ability to develop and implement strategies, programs, policies, and procedures relating to area of responsibility.

Analyze budget and technical reports; interpret and evaluate staff reports; know laws, regulations and codes; observe performance and evaluate staff; resolve unit problems and related issues; and explain and interpret policy.

ADDITIONAL INFORMATION:

Work is mainly performed in the field or an office and meeting room environment. On occasion, the position requires the ability to travel on District business and to visit and inspect District facilities and projects that require traversing uneven or difficult terrain, in all types of weather conditions.

The duties of the position require the ability to walk, observe, talk, listen, and operate a computer and telephone.

Occasionally, work requires lifting or moving up to 35 pounds.

Work hours are irregular and include evening meetings.

OTHER REQUIREMENTS:

Possession of certification as a Grade 2 California Distribution Operator and/or Grade 2 California Water Treatment Operator and a Grade 2 Wastewater Certificate. A Grade 3 Water/Wastewater is preferable.

Possession of a valid California driver's license.

Garberville Sanitary District

Job Description

Job Title: Operations Manager Reports To: Board of Directors Date: August 2012 Job Duties and Responsibilities

- The Operations Manager will supervise the Water Treatment and Distribution along with the Wastewater Treatment and Collections operators to coordinate all field activities necessary to effectively maintain and operate the District.
- The Operations Manager will work with the Business Manager General Manager to assure District policies are implemented.
- The Operations Manager will work with the Business Manager and Project General Manager to assist in the review of projects, designs, technical issues, and project management.
- The Operations Manager shall schedule jobs, assign tasks, and coordinate all aspects of each operation ensuring safety, efficiency, costeffectiveness, and timely completion of projects or assignments.
- The Operations Manager will be required to attend meetings during other than normal work hours. And may be called back to work before or after regularly scheduled work hours or on scheduled days off.
- The Operations Manager shall complete annual performance evaluations on those employees he supervises. He/she shall make recommendations for hiring, firing, promotions, raises, and disciplinary action.
- Commitment to teamwork among peers and subordinates.

61

- The Operations Manager will be responsible for Field Staff and Operators
- Responsible for all reports and compliance of permits and regulations
- Promotes worker professionalism - Serve as a role model, mentor, and coach to ensure employees treat each other and the customers we serve with respect.
- Maintains knowledge and ensures compliance with current employment laws and regulations.
- Performs customer service tasks along with construction and maintenance work.
- Assures that all necessary repairs and maintenance are scheduled and completed on vehicles and equipment
- Oversees the work order system to assure proper record keeping is completed and filed.
- Schedule and assigns daily work to the operation personnel.
- Keeps the Business General Manager and Board of Directors informed of field operations and potential operational problems.
- Assures the water storage facilities (tanks) are properly operated, maintained, and cleaned.
- Assures the water distribution system (mains, valves,

hydrants, and appurtenances) is properly operated, maintained, and cleaned. Assures that the cross connection program is up to date and in accordance with State regulations. Assures the wastewater facilities (pump stations and buildings) are properly operated, maintained, and cleaned. Assures that mapping is maintained and up-to-date. Assures that developer extensions of the water system are in accordance with the District approved plans and are inspected by District personnel. Assures District contract improvements are inspected and completed as per plans and specifications. Assures that customer complaints are responded to in a timely manner, investigated as necessary, and coordinated with the Office General Manager Supervises the District safety program.

62 Assure subordinate employee compliance with all District policies

WATER-2, WASTEWATER-2, DISTRIBUTION-2 OPERATOR

This position is involved with the operations of District treatment plant facilities and the performance of the various duties that are required for the maintenance of treatment plant functions. The prime objective of this position is to help assure a high quality, safe potable water for delivery to the District's customers at all times.

This is skilled work in the treatment of water/wastewater and the operation of water/wastewater treatment plant equipment. The employee is responsible on an assigned shift for the operation of water/wastewater treatment equipment, collecting and testing water samples, analysis of field samples, recording of data and adjusting chemical feed equipment for proper operation. Work is performed under the guidance of the Senior Water Treatment Plant Operator .

EXAMPLES OF DUTIES:

Monitors the various instruments, analyzers, charts, gauges, chemical feeders, pumps, and general mechanical equipment; takes appropriate action to remedy adverse situations.

Computes chemical dosages and adjusts chemical feed machines for proper operation and application of chemicals in order to assure a high quality water effluent standard.

Maintains flows through the plant that will insure an adequate supply of water in the clear well for distribution in the system to meet normal and emergency consumer demands.

Performs chemical and bacteriological tests on water/wastewater samples and records the data thus obtained.

Controls filter operations; places them in service and removes them from service at the proper time for backwashing.

Observes and adjusts filter rate of flow controllers to maintain proper rate of filtration in relation to flow.

Assists in unloading and storing chemicals. During deliveries must assure that the unloading is done properly, with caution, and that the chemicals are placed into the proper tanks.

Washes, cleans, and sterilizes laboratory utensils and equipment, prepares laboratory reagents when required.

Responsible for safe plant conditions and working environment at all times (e.g., the safe handling and hookup of one ton chlorine cylinders). Also responsible for plant security.

Answers customer inquiries; makes every effort to enhance good public relations.

May be called on outside regular assigned shift for emergencies or to help conduct plant tours.

May act in a central communications function as follows: taking, relaying, transmitting, and providing information to and from District personnel on outside emergency services as required.

MINIMUM QUALIFICATIONS:

EDUCATION: Completion of twelfth grade.

EXPERIENCE: Specialized training or equivalent experience in water treatment, or a related field acceptable to management.

KNOWLEDGE, SKILLS & ABILITIES:

Considerable familiarity with the principles practices, materials, equipment water chemistry, and bacteriology associated with water purification; ability and aptitude for making minor mechanical adjustments and repairs requiring immediate attention.

Ability to establish and maintain effective working relations with associates and the public.

ADDITIONAL INFORMATION:

Must successfully pass a physical examination before employment with the District.

OTHER REQUIREMENTS:

GSD requires that Water/Wastewater Treatment Plant Operators possess a minimum Grade II Certification before recognition as qualified plant operators.

Must have a valid California driver's license and a satisfactory driving record.

ESSENTIAL FUNCTION Under direct supervision, responsible for performing water and wastewater treatment processing work duties in conformance with routine processes, treatment methods and in conformance with regulations and standard work and safety techniques.

PRIMARY DUTIES This is an entry level technical water and wastewater treatment classification. This position reports to the Chief Operator or General Manager. **System Operations:** Reviews readings, logs and test results to determine current status of systems and plant processes. Reads, records, interprets and monitors meters, gauges, control panels and laboratory test results to assess system functions and determine processing requirements. Operates direct and remote controls of manual and automatic equipment to start and stop pumps, engines, generators, valves and other equipment and devices which control and adjust power, water or wastewater conveyance, flow, treatment, discharge and biosolids removal processes. Extracts water and/or wastewater samples; prepares State required reports and maintains associated control records; transfer samples to laboratory and performs routine laboratory tests and analyses. Assists in applying chemicals to treatment processes. **Facilities Maintenance:** Identifies and assists in diagnosing existing and potential repair requirements to plant, wells,

pump stations, power generators and all related facilities and equipment. Performs routine scheduled preventive maintenance work and maintenance on equipment. Prepares maintenance and repair service requests. Assists external contractors and internal repair crews to locate, evaluate, adjust, maintain and/or replace equipment, systems and facilities. Maintains central and remote work places. Performs maintenance work on facilities and grounds as needed. Responds to customer service calls. Assists in conducting field investigations and/or inspections of service conditions at user locations. Takes actions needed to resolve service needs. Prepares reports of service calls and complaints. Responds to utility service alerts. Assists in housekeeping maintenance of work places. General: Participates in the general housekeeping and administrative record keeping, meter reading and assigned tasks by the Chief Operator or General Manager. operations of the operations section. Prepares and presents formal reports and recommendations as appropriate. Inform if new or additional equipment is needed and maintain an inventory of equipment. Perform daily laboratory test and data entries on plant performance and equipment logs. Reports all emergencies with the operations of facilities to the Chief Operator. Other Assigned Duties: Perform other duties assigned which are consistent with the responsibilities of the position and necessary to the operations of the District.

Knowledge of the following is required to perform the essential function:

67

Current practices, equipment and procedures applied to water and wastewater conveyance and treatment systems in the State. Federal, State and local legal and regulatory provisions and related technical terminology applicable to water and wastewater treatment processes. Chemical and biological procedures and tests applied in water and wastewater treatment. Basic construction, assembly and operational norms of hydraulic equipment, power generators, pumps and controls.

5 Safety practice procedures applicable to all aspects of treatment and conveyance systems operations; procedures for using protective gear; and specific procedure applicable in handling and using hazardous materials and chemicals.

Ability to do the following is required to perform the essential function: Extract water and wastewater samples and perform standard laboratory tests. Observe, interpret and record measurements indicated on gauges, meters and similar measuring devices. Perform maintenance on water and wastewater equipment and facilities. Understand, retain and apply written procedures. Understand and explain specific provisions and procedures contained in technical manuals, drawings, specifications, blueprints, layouts and schematics. Exhibit a high customer service priority. Establish and maintain open and honest communications with co-workers at all levels of the organization. Instruct others in specific processes and procedures applied in treatment and equipment operations. Operate vehicles, office computers and field communications equipment. Operate water and wastewater equipment and process controls. Tolerate physical presence of height. Ascend and descend ladders and stairs. Within CALOSHA guidelines, withstand periods of physical exposure to the presence of fumes, odors,

dust and pollen without incapacitating adverse effect. Safely enter and leave confined spaces. Safely transport and lift bulky objects. Basic Qualifications: Must possess a Grade I II certification for operating a Water Treatment facility. At least two (2) years experience in the operation and maintenance of Water Treatment systems. Must obtain Grade II Water Treatment certificate within one (1) year and Must Possess a Grade I Wastewater Treatment certificate in three (3) years. Computer skills, ability to use word processing, spread sheets, and data processing is desirable. If approved by the General Manager or designee, water or wastewater certificates may be obtained within one year after employment. Employment Requirements: A valid California State Class C license must be maintained at all times. Pass physical examination and illegal drug screen. Maintain telephone service and reside within 30 minutes response time to GSD. Be available to assist "on call" operator after normal scheduled work hours as needed. Participate in the Safety Program and be physically able to use safety equipment. Qualifying Training and Experience: A combination of training and experience which demonstrates that a person has obtained the required knowledge and is able to perform the required work. Employment Conditions: Specifications Approved by Board of Directors the General Manager. Fair Labor Standards Act Overtime: Non-Exempt, receives overtime compensation. Appointment and Removal Authority: District Administrator. General Manager