

**GARBERVILLE SANITARY DISTRICT
BOARD OF DIRECTORS MEETING
AGENDA**

**There will be a regular meeting held by the Garberville Sanitary District Board of Directors at the
GSD District Office
919 Redwood DR. Garberville, CA**

**April 24th, 2018
5:00 P.M. – Closed Session
5:30 P.M. – Open Public Session**

Any writings or documents that are public records and are provided to a majority of the governing board regarding an open session item on this agenda will be made available for public inspection in the District Office located at 919 Redwood Dr. during normal business hours.

I. REGULAR MEETING CALLED TO ORDER

II. ESTABLISHMENT OF QUORUM

Rio Anderson___, Linda Brodersen___, Doug Bryan___, Richard Thompson___

III. APPROVAL OF AGENDA - Action to add or delete items from any portion of the agenda or to discuss any consent agenda items must be taken prior to adoption of the agenda.

IV. PUBLIC COMMENT ON ANY ITEM ON THE CLOSED SESSION AGENDA

V. CLOSED SESSION

A. General Manager Evaluation

Public Employee Performance Evaluation (§ 54957)

VI. OPEN SESSION

A. Board Report of action, if any, taken during closed session:

VII. COMMENTS AND QUESTIONS FROM THE AUDIENCE

Up to fifteen minutes of this portion of the meeting are reserved for members of the public to address the Board on items not listed on the agenda and within the jurisdiction of the GSD Board. Speakers are limited to 3 minutes. The GSD Board is prohibited by law from taking action on matters discussed that are not on the Agenda, and no adverse conclusions should be drawn if the GSD Board does not respond to public comment at this time.

General Public / Community Groups

VIII. ANNOUNCEMENTS AND COMMUNICATIONS

REPORTS AND PRESENTATIONS – Routine report of activities, operations, meetings / conferences held and/or attended by Board members, Staff, and General Manager

Operations Staff-

Office Staff-

Board Members-

General Manager—Ralph Emerson Pg. 4

Government Code Section 54954.3 provides that the public will have an opportunity to address the Board on any item described on a regular or special meeting either before or during the consideration of that item. The Board reserves the right to limit the time of presentation by individuals and groups

IX. REGULAR AGENDA ITEMS

A. CONSENT AGENDA

Notice to the Public

All matters listed under Consent Agenda are considered to be routine and all will be enacted by one motion and voice vote. There will be no separate discussion of these items unless the Board of Directors requests items to be removed from the Consent Agenda for separate action. Any items will be considered after the motion to approve the Consent Agenda.

A.1 Approve Financials – Pg. 5-18

A.2 Approve 3/27/18 Regular Meeting Minutes - Pg. 19-21

A.3 Operations Safety Report- Pg. 22-23

Motion:

Second:

Vote:

B. GENERAL BUSINESS – Action items

Notice to the Public

The Board of Directors will allow public comment on agenda items although any person who wishes to speak on an agenda item must submit a request prior to the meeting being called to order. You will be given 5 minutes on each agenda item that you wish to comment and then the Board of Directors will discuss the item amongst themselves with no other public comment.

B.1 Measure Z Funding—Fire hydrant Replacement Pg. 24-27
(discussion-possible action) update

Motion:

Second:

Vote:

B.2 Water Treatment Plant Contact Chamber repairs Pg. 28-35
(discussion-possible action) update

Motion:

Second:

Vote:

B.3 2018/2019 Budget Committee Report Pg. 36
(update)

B.4 Solar Energy Update Pg.37
(discussion—direction)

C. POLICY REVISION / ADOPTION

C.1 Water Ordinance Sec 9.7 Customer Guarantee—Requirements and Deposit Pg. 38-43
(discussion-possible action) Resolution 18-003 (2nd reading)

C.2 Personnel Policy: Organization chart--Introduction—Sec 3.1 Pg. 44-46
(discussion-possible action) (first reading)

Motion:

Second:

Vote:

C.3 Resolution 18-007, Increase Contact Chamber Spending Limit Pg. 47

Motion:

Second:

Vote:

X. ITEMS FOR NEXT BOARD MEETING

1. Rate Study
2. Personnel Policy Update
3. Agricultural Water Use Ordinance –Sec 15.9
4. Final Budget Approval 2018-2019
- 5.

XI. ADJOURNMENT

Posting of Notice at the District Office no later than April 20, 2018: Agenda is emailed to the local newspapers and those who have requested an agenda in writing or e-mail.

In accordance with the Americans with Disabilities Act, if you need a special accommodation to participate, please contact the Garberville Sanitary District Office at (707)923-9566 at least 48 hours in advance.

**Garberville Sanitary District
PO Box 211
Garberville, CA. 95542
(707)923-9566**

GENERAL MANAGER REPORT

Date: April 24, 2018

The District Staff have been experiencing additional requirements of their time as we work on the chlorine contact chamber, fire hydrant replacements, customer needs and phasing out of the winter demands into the additional water demands of summer. We have been able to meet or exceed the expectations and responsibilities because staff is willing to do whatever is expected of them regardless of the time or day.

There has been an unusual amount of (over 15) customer turnover during the past month which has created more work in the office and difficulties updating the emergency call out and contact list but Mary and Jamie have been making the changes necessary to contact all customers and keep them informed through our automated call system.

As summer approaches we are working to clean the sewer collection system, repair leaks and prepare for high water demands. We are concerned about water demands if we have not received the chlorine contact chamber but are working on a temporary plan that would provide an adequate water supply to meet customer needs.

I would like to set up a Strategic Planning Day at some time during May. Are there any days that will not work for you?

Respectfully Submitted:

Ralph Emerson



GARBERVILLE SANITARY DISTRICT

P.O. BOX 211 • GARBERVILLE, CA 95542 • (707) 923-9566

BOARD AGENDA MEMORANDUM

Meeting Date: April 24, 2018
To: Garberville Sanitary District Board of Directors
From: Jennie Short, Consultant Project Manager
Subject: February 2018 Financial Statements

GENERAL OVERVIEW AND FINANCIAL CONSIDERATIONS

The attached Financial Statements are for February 2018. As can be seen on the "Combined Revenue & Expense Report for Board" in the YTD Actual (first 8 months of year) column:

- The total revenue is **\$664,542.75**, which is **\$54,734.75** over budget so far this year
- The total expenses are **\$486,767.24**, which is **\$23,827.24** over budget
- The net income excluding depreciation is **\$177,775.51**, which is **\$30,907.51** over budget (good news)

As can be seen on the "Statement of Cash Flows Report for Board - July through February 2018":

- Net cash increase year to date is **\$34,603.74**
- Expenditures for fixed asset acquisition so far this year total **\$53,035.53**
- Total payments on long term debt so far this year total **\$91,876.45**. We will still need to make the second semi-annual payment on the water loan, and the monthly payments on the Alderpoint Tank Loan and Copier Lease which total about **\$39,450**.

There have been some unanticipated repairs and equipment purchases which include:

Description	Amount
Redwood Dr/Sprowel Creek Rd Repair	14,612.72
SWTP Backwash Pumps & RW Check Valves	5,451.90
Main Tank Distribution Pumps	10,197.36
Sunnybank Lane Valves	4,026.98
Measure Z Fire Hydrant Project	10,000
Attorney & CPA fees	14,500
TOTAL	58,788.96

These expenditures will necessitate postponing purchasing the trailer, installing the dual LMI pumps at the SWTP, and telemetry upgrades to Wallen Road, Arthur Road, Alderpoint Road Tanks and the WWTP until a future fiscal year. This will save the District approximately \$33,600 to offset the list above.

In addition, the \$54,734.75 in excess revenue will more than cover the rest, leaving the District with a positive net cash flow so long as the insurance company reimburses the expenses for the replacement of the Chlorine Contact Chamber as they are incurred. If the District has to “front” these expenses beyond 6/30/18 then the financial statement will show a negative cash flow for this year and the reimbursement will show up in next year’s financial statements.

ATTACHMENTS

1. Balance Sheet with Comparison between Current month and Fiscal Year ending June 30, 2017
2. Statement of Cash Flows - Current Month and Fiscal Year to Date
3. Revenue and Expense Report - Combined Report for Water & Sewer containing current month actual, fiscal year to date actual, and annual budget
4. Check Register Report for all checks issued in February 2018

Garberville Sanitary District
Statement of Cash Flows Report for Board
July 1, 2017 through Feb 28, 2018

	Feb 2018	Year to Date	Notes
OPERATING ACTIVITIES			
Net Income	(31,058.50)	(170,571.13)	
Adjustments to reconcile Net Income to net cash provided by operations:			
11000 · Accounts Receivable - Other	0.00	599.70	
1100 · Accounts Receivable	(1,401.98)	15,883.56	
1110 · Accts Receivable Over Payments	(1,177.85)	1,825.79	
1120 · A/R - Employee	91.97	0.00	
1450 · Prepaid Rent	0.00	835.00	
1500 · Prepaid Insurance	1,911.23	(5,355.15)	
1501 · Prepaid Workers Comp	672.32	7,442.84	
1502 · Prepaid Expenses	549.18	4,393.44	
1510 · Prepaid Licenses and Permits	1,635.00	(6,582.06)	
2000 · Accounts Payable	(5,700.51)	(13,984.26)	
20000 · *Accounts Payable	0.00	(1,227.86)	
2205 · Accrued Simple	0.00	(41.46)	
2220 · Accrued State PR Taxes	0.00	(29.71)	
2225 · Accrued Workers Comp	0.00	(2,019.62)	
Net cash provided by Operating Activities	(34,479.14)	(168,830.92)	
INVESTING ACTIVITIES			
SEWER:Collection	0.00	(14,888.32)	
Accumulated Depreciation-Water	28,765.08	230,120.64	
Accumulated Depreciation-Sewer	14,778.25	118,226.00	
CIP-CL2 Contact Chamber Replace	(1,137.50)	(10,941.01)	
CIP - Bear Canyon Aerial	0.00	(1,529.96)	
WATER:Treatment	0.00	(5,451.90)	
WATER:Distribution	0.00	(16,197.36)	
SEWER:Pumps	0.00	(4,026.98)	
Net cash provided by Investing Activities	42,405.83	295,311.11	
FINANCING ACTIVITIES			
2500 · N/P - SWRCB	0.00	(22,713.22)	
2605 · RCAC Loan #6200-GSD-02	(4,095.84)	(32,294.80)	
2655 · Lease Payable - Copier	(81.12)	(638.07)	
2700 · SRF Loan - Water	0.00	(22,991.18)	
2660 · Lease Payable - Ford Motor Cred	0.00	(13,239.18)	
Net cash provided by Financing Activities	(4,176.96)	(91,876.45)	
Net cash increase for period	3,749.73	34,603.74	Net Positive :)
Cash at beginning of period	839,117.70	808,263.69	
Cash at end of period	842,867.43	842,867.43	

Garberville Sanitary District
Balance Sheet Prev Year Comparison

As of February 28, 2018

	Jun 30, 17	Feb 28, 18	\$ Change June 30 - Feb 28	Notes
ASSETS				
Current Assets				
Checking/Savings				
1005 · Umpqua Checking - Operating	13,489.99	32,437.31	18,947.32	
1006 · Umpqua System Reserve - Water	56,039.48	75,920.54	19,881.06	
1007 · Umpqua System Reserve - Sewer	80,228.22	58,368.78	(21,859.44)	
1011 · Water Enterprise Fund	46,354.75	46,462.87	108.12	
1030 · County Treasury - Sewer Reserve	373,134.13	388,962.96	15,828.83	1st Inst. Of Prop Taxes
1031 · County Treasury - Water Reserve	238,854.09	240,393.83	1,539.74	
1040 · Petty Cash	39.51	39.51	0.00	
1050 · Cash Drawer	200.00	281.63	81.63	
Total Checking/Savings	808,340.17	842,867.43	34,527.26	
Accounts Receivable				
11000 · Accounts Receivable - Other	814.70	215.00	(599.70)	
Total Accounts Receivable	814.70	215.00	(599.70)	
Other Current Assets				
1100 · Accounts Receivable				
1110 · Accts Receivable Over Payments	(1,481.30)	(3,307.09)	(1,825.79)	
1100 · Accounts Receivable - Other	99,758.38	83,874.82	(15,883.56)	
Total 1100 · Accounts Receivable	98,277.08	80,567.73	(17,709.35)	
1120 · A/R - Employee	0.00	0.00	0.00	
1450 · Prepaid Rent	835.00	0.00	(835.00)	
1500 · Prepaid Insurance	2,468.34	7,823.49	5,355.15	
1501 · Prepaid Workers Comp	10,225.31	2,782.47	(7,442.84)	
1502 · Prepaid Expenses	6,590.16	2,196.72	(4,393.44)	
1510 · Prepaid Licenses and Permits	0.00	6,582.06	6,582.06	
1550 · Allowance for Doubtful Accounts	(5,000.00)	(5,000.00)	0.00	
Total Other Current Assets	113,395.89	94,952.47	(18,443.42)	
Total Current Assets	922,550.76	938,034.90	15,484.14	
Fixed Assets				
CIP-CL2 Contact Chamber Replace	0.00	10,941.01	10,941.01	Emergency Project
CIP - SWTP Coag Project	4,806.26	4,806.26	0.00	
CIP - Leino Ln	585.00	585.00	0.00	
CIP - Bear Canyon Aerial	1,236.10	2,766.06	1,529.96	
WATER				
Land - Water	88,698.62	88,698.62	0.00	
Water Easements & Intangibles	177,397.11	177,397.11	0.00	
Treatment	59,930.27	65,382.17	5,451.90	SWTP BW Pump and RW Check Valve
Distribution	2,696,416.81	2,712,614.17	16,197.36	Main Tank Dist Pumps
Pumps	2,909.87	2,909.87	0.00	
DWTP (Water) 2015	4,968,104.88	4,968,104.88	0.00	
Total WATER	7,993,457.56	8,015,106.82	21,649.26	

Garberville Sanitary District
Balance Sheet Prev Year Comparison

As of February 28, 2018

	Jun 30, 17	Feb 28, 18	\$ Change June 30 - Feb 28	Notes
Water System	142,474.97	142,474.97	0.00	
SEWER			0.00	
Land - Sewer	129,810.68	129,810.68	0.00	
Collection	2,311,580.70	2,326,469.02	14,888.32	Headworks Flow
Treatment	507,552.59	507,552.59	0.00	
Pumps	9,881.98	13,908.96	4,026.98	Sunnybank Valve
Sewer Project - 2011	2,792,451.91	2,792,451.91	0.00	
Total SEWER	5,751,277.86	5,770,193.16	18,915.30	
Office Equipment	32,004.40	32,004.40	0.00	
Equipment	158,306.60	158,306.60	0.00	
Vehicles	81,171.66	81,171.66	0.00	
MSR/SOI and Annexation Project	157,367.08	157,367.08	0.00	
Accumulated Depreciation-Water	(1,183,142.26)	(1,413,262.90)	(230,120.64)	
Accumulated Depreciation-Sewer	(1,636,657.06)	(1,754,883.06)	(118,226.00)	
Total Fixed Assets	11,502,888.17	11,207,577.06	(295,311.11)	
TOTAL ASSETS	12,425,438.93	12,145,611.96	(279,826.97)	
LIABILITIES & EQUITY				
Liabilities				
Current Liabilities				
Accounts Payable				
2000 · Accounts Payable	26,541.07	12,430.98	(14,110.09)	
Total Accounts Payable	26,541.07	12,430.98	(14,110.09)	
Other Current Liabilities				
20000 · *Accounts Payable	1,227.86	0.00	(1,227.86)	
2205 · Accrued Simple	0.00	(41.46)	(41.46)	
2220 · Accrued State PR Taxes	29.71	0.00	(29.71)	
2225 · Accrued Workers Comp	2,019.62	0.00	(2,019.62)	
2230 · Accrued Vacation	16,720.85	16,720.85	0.00	
2250 · Loans Payable - Current Portion	131,750.84	131,750.84	0.00	
Total Other Current Liabilities	151,748.88	148,430.23	(3,318.65)	
Total Current Liabilities	178,289.95	160,861.21	(17,428.74)	
Long Term Liabilities				
2500 · N/P - SWRCB	168,855.28	146,142.06	(22,713.22)	Full Year Pmt made
2605 · RCAC Loan #6200-GSD-02	177,471.14	145,176.34	(32,294.80)	8 of 12 pmts
2655 · Lease Payable - Copier	2,526.29	1,888.22	(638.07)	8 of 12 pmts
2660 · Lease Payable - Ford Motor Cred	27,338.94	14,099.76	(13,239.18)	Full Year Pmt made
2700 · SRF Loan - Water	1,310,497.46	1,287,506.28	(22,991.18)	1 of 2 pmts made
2900 · Less Current Portion	(131,750.84)	(131,750.84)	0.00	
Total Long Term Liabilities	1,554,938.27	1,463,061.82	(91,876.45)	
Total Liabilities	1,733,228.22	1,623,923.03	(109,305.19)	
Equity				
3000 · Contributed Capital	6,129,491.75	6,129,491.75	0.00	
3100 · Retained Earnings	4,845,044.92	4,562,768.31	(282,276.61)	
Net Income	(282,325.96)	(170,571.13)	111,754.83	
Total Equity	10,692,210.71	10,521,688.93	(170,521.78)	
TOTAL LIABILITIES & EQUITY	12,425,438.93	12,145,611.96	(279,826.97)	

Garberville Sanitary District
Combined Revenue & Expense Report for Board
February 2018

	February 2018 Actual	YTD Actual	YTD Budget	Total Annual Budget	YTD Actual to Budget Difference	Notes
Ordinary Income/Expense						
Income						
Water Charges						
4100 · Residential	20,280.92	199,593.64	191,997.00	290,000.00	-7,596.64	Extra water use
4110 · Commercial	16,538.50	156,582.02	141,860.00	215,000.00	-14,722.02	Extra water use
4150 · Bulk Water Sales	0.00	22,764.00			-22,764.00	Unplanned Revenue
Total Water Charges	36,819.42	378,939.66	333,857.00	505,000.00	-45,082.66	
4200 · Sewer Charges	28,376.80	241,821.52	243,463.00	365,000.00	1,641.48	
4300 · Connection Fees	0.00	16,000.00	16,000.00	64,000.00	0.00	
4650 · Late Charges	490.00	4,125.00	3,333.00	5,000.00	-792.00	
4700 · Other Operating Revenue	460.00	5,706.50	137.00	200.00	-5,569.50	Reconnection fees
49900 · Uncategorized Income	0.00	135.00			-135.00	Bid package pmt
Total Income	66,146.22	646,727.68	596,790.00	939,200.00	-49,937.68	
Expense						
Administrative and General						
5000 · Advertising	0.00	0.00	233.00	350.00	233.00	
5005 · Bad Debts	432.33	962.52	3,665.00	5,500.00	2,702.48	
5010 · Bank Charges						
5012 · Merchant Account Fees	90.88	1,432.69	998.00	1,500.00	-434.69	More CC pmts
5010 · Bank Charges - Other	0.00	979.64	900.00	1,350.00	-79.64	
Total 5010 · Bank Charges	90.88	2,412.33	1,898.00	2,850.00	-514.33	
5020 · Directors Fees	0.00	2,900.00	1,200.00	1,800.00	-1,700.00	16/17 paid in 17/18
						CSDA \$1622 -> \$2658
5030 · Dues and Memberships	180.00	4,360.27	2,136.00	3,200.00	-2,224.27	Rotary \$180 Qtly
5035 · Education and Training	0.00	655.00	2,264.00	3,400.00	1,609.00	
5036 · Education and Training - B.O.D.	0.00	0.00	201.00	299.00	201.00	
Insurance						
5040 · Liability	1,911.23	15,289.84	13,768.00	20,649.00	-1,521.84	Comprehensive on autos
5050 · Workers' Comp	672.32	7,442.84	10,400.00	15,600.00	2,957.16	Corrections on Admin wage

Garberville Sanitary District
Combined Revenue & Expense Report for Board
February 2018

	February 2018 Actual	YTD Actual	YTD Budget	Total Annual Budget	YTD Actual to Budget Difference	Notes
5055 · Health						
5055.1 · Employee Portion	-607.62	-5,164.77	-4,785.00	-7,177.00	379.77	
5055 · Health - Other	2,603.85	20,153.25	23,927.00	35,890.00	3,773.75	Mary 1/2 year; budgeted for full year
Total 5055 · Health	1,996.23	14,988.48	19,142.00	28,713.00	4,153.52	
Total Insurance	4,579.78	37,721.16	43,310.00	64,962.00	5,588.84	
5060 · Licenses, Permits, and Fees	1,635.00	14,999.69	14,800.00	22,200.00	-199.69	
5065 · Auto	0.00	454.44	3,332.00	4,000.00	2,877.56	
5070 · Miscellaneous	-6.00	56.58	67.00	101.00	10.42	
5080 · Office Expense	83.97	4,470.70	3,736.00	5,600.00	-734.70	
5085 · Outside Services	622.67	5,295.55	5,985.00	11,344.00	689.45	
5090 · Payroll Taxes	2,252.71	16,731.33	19,260.00	28,890.00	2,528.67	
5100 · Postage	417.98	1,714.78	1,732.00	2,596.00	17.22	
5110 · Professional Fees	5,638.30	56,256.57	40,000.00	60,000.00	-16,256.57	Attorney, CPA transition
5130 · Rents	835.00	7,515.00	7,160.00	10,740.00	-355.00	
5135 · Retirement	571.88	4,954.27	4,948.00	7,422.00	-6.27	
5137 · Supplies	37.66	741.56	1,800.00	2,700.00	1,058.44	
5140 · Telephone	647.14	3,830.92	1,865.00	2,800.00	-1,965.92	Moved from Utilities
5145 · Tools	0.00	596.33	3,333.00	4,000.00	2,736.67	
5150 · Travel and Meetings	0.00	1,018.46	1,064.00	1,600.00	45.54	
5155 · Utilities	213.33	1,585.42	1,600.00	2,400.00	14.58	
5160 · Wages						
5165 · Wages - Overtime	52.14	1,590.22	0.00	0.00	-1,590.22	
5160 · Wages - Other	9,882.31	81,403.49	82,762.00	124,144.00	1,358.51	
Total 5160 · Wages	9,934.45	82,993.71	82,762.00	124,144.00	-231.71	
Total Administrative and General	28,167.08	252,226.59	248,351.00	372,898.00	-3,875.59	
Sewage Collection						
6010 · Fuel	196.22	1,249.54	1,900.00	2,850.00	650.46	
6030 · Repairs and Maintenance	139.21	4,490.73	13,334.00	20,000.00	8,843.27	
6040 · Supplies	92.17	1,878.16	1,068.00	1,600.00	-810.16	Hypo rate went up Wilcox rock/AC stockpile

Garberville Sanitary District
Combined Revenue & Expense Report for Board
February 2018

	February 2018 Actual	YTD Actual	YTD Budget	Total Annual Budget	YTD Actual to Budget Difference	Notes
6050 · Utilities	288.03	2,873.04	3,268.00	4,900.00	394.96	Telephone
6060 · Wages						
6065 · Wages - Overtime Sewer Collec	132.00	700.50	1,332.00	2,000.00	631.50	
6060 · Wages - Other	2,774.52	21,778.68	12,520.00	18,776.00	-9,258.68	
Total 6060 · Wages	2,906.52	22,479.18	13,852.00	20,776.00	-8,627.18	
Sewage Collection - Other	0.00	6.26			-6.26	
Total Sewage Collection	3,622.15	32,976.91	33,422.00	50,126.00	445.09	
Sewage Treatment						
6075 · Fuel	196.22	1,249.54	1,732.00	2,600.00	482.46	
6080 · Monitoring	272.50	2,048.23	5,333.00	8,000.00	3,284.77	
6100 · Repairs and Maintenance	2,650.00	9,209.78	8,332.00	12,500.00	-877.78	
6110 · Supplies	0.00	3,275.70	5,068.00	7,600.00	1,792.30	
6120 · Utilities	774.79	6,580.66	8,000.00	12,000.00	1,419.34	Telephone
6130 · Wages						
6135 · Wages - Overtime Sewer Treati	0.00	1,033.50	1,000.00	1,500.00	-33.50	
6130 · Wages - Other	2,812.14	19,568.63	21,268.00	31,900.00	1,699.37	
Total 6130 · Wages	2,812.14	20,602.13	22,268.00	33,400.00	1,665.87	
Total Sewage Treatment	6,705.65	42,966.04	50,733.00	76,100.00	7,766.96	
Water Trans and Distribution						
7075 · Fuel	196.22	1,249.54	1,668.00	2,500.00	418.46	
7090 · Repairs and Maintenance	314.10	20,823.52	10,000.00	15,000.00	-10,823.52	SCR & Redwood Dr
7100 · Supplies	58.72	2,039.78	2,668.00	4,000.00	628.22	
7110 · Utilities	304.43	4,723.06	6,000.00	9,000.00	1,276.94	Telephone
7120 · Wages						
7125 · Wages - Overtime Water Trans	169.50	4,021.00	3,000.00	4,500.00	-1,021.00	
7120 · Wages - Other	3,264.91	31,100.89	18,909.00	28,364.00	-12,191.89	
Total 7120 · Wages	3,434.41	35,121.89	21,909.00	32,864.00	-13,212.89	
Total Water Trans and Distribution	4,307.88	63,957.79	42,245.00	63,364.00	-21,712.79	

Garberville Sanitary District
Combined Revenue & Expense Report for Board
February 2018

	February 2018 Actual	YTD Actual	YTD Budget	Total Annual Budget	YTD Actual to Budget Difference	Notes
Water Treatment						
7020 · Fuel	196.22	1,249.56	2,000.00	3,000.00	750.44	
7010 · Monitoring	272.50	4,401.87	3,332.00	5,000.00	-1,069.87	HACH equip \$2,336.38
7030 · Repairs and Maintenance	705.20	13,500.13	3,332.00	5,000.00	-10,168.13	2 Valves for SWTP Filer
7040 · Supplies	2,436.40	8,588.18	8,000.00	12,000.00	-588.18	
7050 · Utilities	2,798.89	25,755.35	26,668.00	40,000.00	912.65	Telephone
7060 · Wages						
7065 · Wages - Overtime Water Treat	198.00	4,948.25	3,334.00	5,000.00	-1,614.25	CL2 Emergency
7060 · Wages - Other	3,668.57	25,509.16	30,960.00	46,440.00	5,450.84	
Total 7060 · Wages	3,866.57	30,457.41	34,294.00	51,440.00	3,836.59	
Total Water Treatment	10,275.78	83,952.50	77,626.00	116,440.00	-6,326.50	
Total Expense	53,078.54	476,079.83	452,377.00	678,928.00	-23,702.83	
Net Ordinary Income	13,067.68	170,647.85	144,413.00	260,272.00	-26,234.85	
Other Income/Expense						
Other Income						
Property Tax Revenue						
8010 · Secured	0.00	12,284.19	11,500.00	23,000.00	-784.19	
8020 · Unsecured	0.00	833.93	750.00	1,500.00	-83.93	
8025 · Prior Years	0.00	0.00	0.00	25.00	0.00	
8030 · Supplemental - Current	0.00	128.12	75.00	150.00	-53.12	
8035 · Supplemental - Prior Years	0.00	25.92	25.00	50.00	-0.92	
Total Property Tax Revenue	0.00	13,272.16	12,350.00	24,725.00	-922.16	
8053 · Water Capital Grant Income	0.00	0.00	0.00	60,000.00	0.00	
8060 · Interest Income	48.51	4,373.81	668.00	1,000.00	-3,705.81	Budget Incorrect
8070 · Other Non-Operating Revenue	0.00	10.54			-10.54	
9030 · Homeowners' Tax Relief	0.00	158.56	0.00	350.00	-158.56	
Total Other Income	48.51	17,815.07	13,018.00	86,075.00	-4,797.07	

Garberville Sanitary District
Combined Revenue & Expense Report for Board
February 2018

	February 2018 Actual	YTD Actual	YTD Budget	Total Annual Budget	YTD Actual to Budget Difference	Notes
Other Expense						
9040 · Depreciation	43,543.33	348,346.64	350,000.00	525,000.00	1,653.36	
9050 · Interest Expense	631.36	10,687.41	10,563.00	15,843.00	-124.41	
Total Other Expense	44,174.69	359,034.05	360,563.00	540,843.00	1,528.95	
Net Other Income	-44,126.18	-341,218.98	-347,545.00	-454,768.00	-6,326.02	
Net Income	-31,058.50	-170,571.13	-203,132.00	-194,496.00	-32,560.87	
9040 · Depreciation	43,543.33	348,346.64	350,000.00	525,000.00	-1,653.36	
Net Income Excluding Depreciation	12,484.83	177,775.51	146,868.00	330,504.00	30,907.51	

Total Revenue		664,542.75	609,808.00	1,025,275.00	54,734.75	Over Budget - good
Total Expense		486,767.24	462,940.00	694,771.00	23,827.24	Over Budget - bad
Net Income		177,775.51	146,868.00	330,504.00	30,907.51	Over Budget - good
Payroll - RT	22,402.45	179,360.85	166,419.00	249,624.00	12,941.85	Over Budget - bad
Payroll - OT	551.64	12,293.47	8,666.00	13,000.00	3,627.47	Not above Annual

10:44 AM

04/16/18

Accrual Basis

Garberville Sanitary District
Check Register Report for Board
 February 2018

Date	Num	Memo	Amount
101 Netlink			
02/21/2018	9216		-310.00
Total 101 Netlink			-310.00
Anderson, Lucas, Somerville & Borges			
02/21/2018	9217		-6,250.00
Total Anderson, Lucas, Somerville & Borges			-6,250.00
Blue Star Gas			
02/21/2018	9218		-69.28
Total Blue Star Gas			-69.28
Branscomb Center			
02/16/2018	DBT		-37.69
Total Branscomb Center			-37.69
Brian Miller			
02/14/2018	9203		-119.94
Total Brian Miller			-119.94
Candor Rock, LLP			
02/14/2018	9204		-807.50
Total Candor Rock, LLP			-807.50
Capital Bank & Trust			
02/05/2018	EFT	557880519	-722.49
02/05/2018	EFT	025158148	-289.29
02/20/2018	EFT	025158148	-282.59
02/20/2018	EFT	557880519	-705.78
Total Capital Bank & Trust			-2,000.15
Cash			
02/07/2018	9209		-15.00
02/13/2018	9202		-24.00
Total Cash			-39.00
Coast To Coast			
02/08/2018	9190		-416.99
Total Coast To Coast			-416.99
Crystal Springs Bottled Water			
02/08/2018	9191		-5.00
Total Crystal Springs Bottled Water			-5.00
Dazey's Building Center			
02/14/2018	9205		-57.06
Total Dazey's Building Center			-57.06
DialMyCalls			
02/26/2018	DEBIT		-100.00
02/27/2018	DBT	VOID: GJE, RGJE created on 04/05/2018	0.00
Total DialMyCalls			-100.00
EDD			
02/05/2018	EFT	499-0538-3	-578.09
02/05/2018	EFT	499-0538-3	-399.63
02/20/2018	EFT	499-0538-3	-541.85
02/20/2018	EFT	499-0538-3	-97.09
Total EDD			-1,616.66

Garberville Sanitary District
Check Register Report for Board
February 2018

Date	Num	Memo	Amount
Fluentstream Tech			
02/08/2018	9192	VOID:	0.00
Total Fluentstream Tech			0.00
Frontier Communications			
02/21/2018	9219		-9.41
Total Frontier Communications			-9.41
Garberville Rotary			
02/21/2018	9220		-180.00
Total Garberville Rotary			-180.00
Humboldt Fence Co.			
02/14/2018	9206		-2,650.00
Total Humboldt Fence Co.			-2,650.00
IRS			
02/05/2018	EFT	68-0296323	-2,749.38
02/20/2018	EFT	68-0296323	-2,530.60
Total IRS			-5,279.98
Jamie Corsetti, CPA			
02/12/2018	9199		-900.00
Total Jamie Corsetti, CPA			-900.00
Jennie Short			
02/26/2018	9224		-3,169.09
Total Jennie Short			-3,169.09
KEENAN SUPPLY			
02/26/2018	9225		-145.26
Total KEENAN SUPPLY			-145.26
Lori Ruiz			
02/26/2018	9226		-200.00
Total Lori Ruiz			-200.00
MILT'S SAW SHOP			
02/21/2018	9221		-37.66
Total MILT'S SAW SHOP			-37.66
Mitchell, Brisso, Delaney & Vrieze			
02/08/2018	9193		-1,275.31
Total Mitchell, Brisso, Delaney & Vrieze			-1,275.31
NAPA			
02/08/2018	9194		-153.01
02/15/2018	9210		-16.57
Total NAPA			-169.58
North Coast Laboratories Ltd.			
02/14/2018	9207		-60.00
Total North Coast Laboratories Ltd.			-60.00
PAPER MILL			
02/08/2018	9195		-90.90
Total PAPER MILL			-90.90

Garberville Sanitary District
Check Register Report for Board
 February 2018

Date	Num	Memo	Amount
PG&E			
02/08/2018	9196		-2,770.14
02/08/2018	9197		-1,878.91
Total PG&E			-4,649.05
Pitney Bowes Purchase Power			
02/21/2018	9222		-417.98
Total Pitney Bowes Purchase Power			-417.98
Ralph Emerson			
02/21/2018	9223		-50.00
Total Ralph Emerson			-50.00
Recology Humboldt County			
02/14/2018	9208		-24.00
Total Recology Humboldt County			-24.00
Redwood Merchant Services			
02/21/2018	9303		-75.42
02/28/2018			-90.88
Total Redwood Merchant Services			-166.30
RENNER			
02/10/2018	DBT		-784.88
Total RENNER			-784.88
Rural Community Assistance Program			
02/01/2018	DBT		-4,717.81
Total Rural Community Assistance Program			-4,717.81
SDRMA			
02/08/2018	9198		-2,337.84
02/26/2018	9227		-266.01
Total SDRMA			-2,603.85
Sentry III Center			
02/26/2018	9228		-835.00
Total Sentry III Center			-835.00
Streamline			
02/01/2018	9182		-100.00
Total Streamline			-100.00
Umpqua Bank			
02/02/2018	9302	Monthly maintenance analysis fee	-158.06
Total Umpqua Bank			-158.06
US Cellular			
02/01/2018	9183		-250.58
Total US Cellular			-250.58
Wells Fargo			
02/12/2018	9200		-90.51
Total Wells Fargo			-90.51
Wyatt & Whitchurch, E.A. Inc.			
02/12/2018	9201		-2,370.00
Total Wyatt & Whitchurch, E.A. Inc.			-2,370.00

10:44 AM

04/16/18

Accrual Basis

Garberville Sanitary District
Check Register Report for Board
February 2018

<u>Date</u>	<u>Num</u>	<u>Memo</u>	<u>Amount</u>
Arreguin, Daniel J			
02/05/2018	9184		-1,959.94
02/20/2018	9211		-1,901.25
Total Arreguin, Daniel J			-3,861.19
Emerson, Ralph K			
02/05/2018	9185		-2,946.20
02/20/2018	9212		-2,946.21
Total Emerson, Ralph K			-5,892.41
LaFond, Jamie L			
02/05/2018	9186		-456.70
02/20/2018	9213		-358.60
Total LaFond, Jamie L			-815.30
Miller, Brian A			
02/05/2018	9187		-1,653.62
02/20/2018	9214		-1,576.62
Total Miller, Brian A			-3,230.24
Nieto, Mary			
02/05/2018	9188		-1,158.83
02/20/2018	9215		-960.04
Total Nieto, Mary			-2,118.87
Ruiz, Ricardo			
02/05/2018	9189		-356.26
Total Ruiz, Ricardo			-356.26
TOTAL			-59,488.75

**GARBERVILLE SANITARY DISTRICT
BOARD OF DIRECTORS MEETING
MINUTES**

March 27, 2018

5:00 P.M. – Closed Session

5:15 P.M. – Open Public Session

I. REGULAR MEETING CALLED TO ORDER

Open Session was called to order @ 5:25 pm

II. ESTABLISHMENT OF QUORUM

Rio Anderson -Absent

Linda Brodersen-Present

Doug Bryan

Richard Thompson

III. APPROVAL OF AGENDA

Motion: Richard Thompson

Second: Doug Bryan

Vote: 3-0

IV. PUBLIC COMMENT ON ANY ITEM ON THE CLOSED SESSION AGENDA

V. CLOSED SESSION

A. Conference with Legal Counsel-Anticipated Litigation. Significant exposure to litigation pursuant to paragraph (2) of subdivision (d) of Government Code Section 54956.9: One Potential Case: The receipt of a written employment/labor law claim pursuant to the California Tort Claims Act dated August 11th, 2017, from Tina Stillwell. (California Government Code § 54956.9(e)(3).

VI. OPEN SESSION

No action was taken in closed session.

VII. COMMENTS AND QUESTIONS FROM THE AUDIENCE

General Public / Community Groups

VIII. ANNOUNCEMENTS AND COMMUNICATIONS

REPORTS AND PRESENTATIONS

Operations Staff- 0

Office Staff- 0

Board Members- Linda requests Sept 18th 2018 BOD meeting be moved to September 20th 2018.

General Manager—Ralph Emerson Pg 4.

Linda and Doug Re-Election in November 2018. Paperwork needs to be filed July 16th through August 10th 2018.

IX. REGULAR AGENDA ITEMS

A. CONSENT AGENDA

A.1 Approve Financials – pg. 5-19

Pull financials for questions from Richard Thompson about budget numbers on certain line items which staff will research and report back.

Motion: Richard Thompson

Second: Doug Bryan

Vote: 3-0

A.2 Approve 2/27/18 Regular Meeting Minutes - pg. 20-22

A.3 Operations Safety Report- pg. 23-24

Motion: Richard Thompson

Second: Doug Bryan

Vote: 3-0

B. GENERAL BUSINESS – Action items

B.1 Measure Z Funding—Fire hydrant Replacement

(discussion-possible action) update

Wahlund Construction won the bid for the fire hydrant replacement project. First hydrant installed at AP tank. Second at South East end of town. Third hydrant to be replaced is on Riverview. The fourth hydrant replaced will be at Calico's. Route 2 was notified of possibility to be without water during the first hydrant replacement.

B.2 Water Treatment Plant Contact Chamber repairs pg.

(discussion-possible action) update

The Engineer is designing an above ground chlorine contact chamber. Contract is written, working on specs and working with our insurance company to be reimbursed.

B.3 Phillipsville-Garberville Operations Agreement pg. 25-27

(discussion-possible action)

Dan Arreguin could possibly work as a private contract operator for Phillipsville Water Company as long as it didn't interfere with GSD work schedule and being approved by the Board and GM.

B.4 Update on Changes to Quick Books Accounting pg.

(Mary report)

Must upgrade the current version of Quickbooks that the District uses because of required upgrades.

B.6 Rate Study Update pg.

B.7 Alternative Electricity Research pg.

RCEA may be interested in purchasing electricity from GSD if the District builds a solar power system. Ralph is in contact with Greenwire and RCEA about meeting with the District.

B.8 CSDA Board Nomination pg. 28-33

(discussion-possible action) Resolution #18-006

It was approved to have Ralph Emerson submit name as a candidate for CSDA Board Member position in an effort to connect with other Districts throughout California and to gather information which benefits GSD.

Motion: Richard Thompson

Second: Doug Bryan

Roll Call Vote: 3-0

C. POLICY REVISION / ADOPTION

C.1 Water Ordinance Sec 9.7 Customer Guarantee—Requirements and Deposit pg. 34-35

(discussion-possible action) Resolution 18-003 (first reading)

Bring back for more discussion

C. POLICY REVISION / ADOPTION-----Continued

C.2 Contact Chamber----Notice of Exemption pg. 36-41

(discussion-possible action) resolution #18-004
Motion: Richard Thompson Second: Doug Bryan

Roll Call Vote: 3-0

C.3 Fire Hydrant Replacement—Notice of Exemption pg. 42-46
(discussion-possible action) resolution #18-005
Motion: Richard Thompson Second: Doug Bryan

Roll Call Vote: 3-0

X. ITEMS FOR NEXT BOARD MEETING

1. Rate Study
2. 10 year Capital Improvement Plan
3. Agricultural Water Use Ordinance –Sec 15.9
4. Budget Update 2018-2019
5. Water Ordinance Sec 9.7 Customer Guarantee—Requirements and Deposit

XI. ADJOURNMENT

@7:02 p.m.

RECEIVED
MAR 29 2018



ATTENDANCE ROSTER

Safety Meeting

Date of Meeting: 4/18/18 Leader Name: Ralph Emerson

Instructions:

- a. Fill in the date of the meeting and the name of the safety meeting leader.
- b. Have all safety meeting participants sign this roster.
(Copy this form if more pages are needed.)
- c. File this roster and the associated documents as outlined in the Leader Discussion Guide.

Name (print)	Name (signature)
1. <u>Ralph Emerson</u>	<u>Ralph Emerson</u>
2. <u>RAJAN Mills</u>	<u>Rajan Mills</u>
3. <u>Dan Acquin</u>	<u>Dan Acquin</u>
4. <u>Mary Nieto</u>	<u>Mary Nieto</u>
5. <u>Jamie LaFond</u>	<u>Jamie LaFond</u>
6. _____	_____
7. _____	_____
8. _____	_____
9. _____	_____
10. _____	_____
11. _____	_____
12. _____	_____
13. _____	_____
14. _____	_____
15. _____	_____
16. _____	_____
17. _____	_____
18. _____	_____
19. _____	_____
20. _____	_____

Attachments: 1. Leader Discussion Guide 2. Safety Meeting Booklet

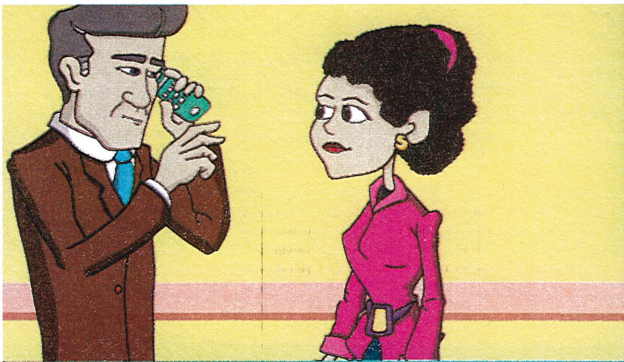

RESPECT FOR PEOPLE











**AMENDMENT TO TERMS AND CONDITIONS OF SALE
AND ASME PRESSURE VESSEL TANK QUOTATION NUMBER 435527**

1. The Garberville Sanitary District, which is within the State of California, is subject to the permitting requirements of Water Permit Number 01-01-12(P)-002 as issued by the State of California. Any modifications to the treatment processes must be approved by the State.

2. In 2013&14 the District built a new surface water treatment plant which included 30" underground serpentine pipes acting as a chlorine contact chamber (CCC). The CCC was sized to accommodate a flow rate of up to 350 GPM at the most extreme treatment conditions. In November 2017, the underground pipes failed and cracked. The District is currently operating under emergency approval utilizing a portion of the distribution lines to provide chlorine contact time during the low flow portion of the year. These failed pipes must be replaced with a CCC that is capable of treating the same 350 GPM on site, and must be approved by the State of California WaterBoard Division of Drinking Water (DDW). The DDW has a list of certified/approved product manufacturers for which no additional testing is required. Any CCC replacement must be accepted and approved by DDW for use in the District's system and meet the requirements of chlorine contact detention time within the footprint of the surface water treatment plant site.

3. The District contracted with Andy Sundquist & David Nicoletti to determine what replacement options were available. As part of their options, a pressure vessel tank from Highland Tank was considered. Highland Tank is not listed on the DDW's list, and therefore the baffled tank must be tested once installed using a tracer test administered by DDW staff to determine the final baffling factor that will be accepted by DDW for this specific tank and the associated chlorine contact detention time calculations. Negotiations ensued culminating in an agreement between the District and Highland tank.

4. The following terms specified below supersede any listed on the quotation, sales contract, or the standard Highland Terms and Conditions:
 - A. The District will pay Highland Tank 25% at the time of ordering tank and 25% at the time that the tank is received. The remaining 50% will be paid within 7 calendar days once the tracer test is completed and the State DDW has certified the tank for a baffling factor of 0.5 or higher.
 - B. Should the tracer test result in a baffling factor less than 0.5, Highland Tank will refund the 50% previous paid by the District within 30 calendar days. Highland Tank will not be responsible for reimbursing the District for the costs associated with installation of the tank.
 - C. Highland Tank staff is more than welcome to attend the tracer testing at their own expense. The District will provide as much notice as we can for the date of such testing, within the limitations that the State will be scheduling the test.

These terms have been accepted by Highland Tank on _____ of April, 2018.

/s/ _____

Name: _____

Title: _____

Company Seal:

Highland Tank & Mfg. Co. ASME PRESSURE VESSEL QUOTATION

TO: GARBERVILLE SANITATION
 PO BOX 211
 919 REDWOOD DRIVE
 GARBERVILLE CA 95542
 Attention: RALPH EMERSON

Payment Terms: All orders subject to credit approval by Highland Tank.
 25% due at time of order; 65% due prior to shipping;
 10% Net 30, for approved accounts.
 All first-time orders under \$2,000 require payment before delivery.

 Estimated Delivery: 13-16 WEEKS
 from date of receipt of approved drawing.

RE: CHLORINE CONTACT

Freight to:

 GARBERVILLE CA

QTY	DESCRIPTION	UNIT PRICE	AMOUNT
1	20000 Gallon ASME Pressure Vessel CHLORINE CONTACT Application: Aboveground Material: SA-516 GR-70 PVQ Diameter: 10'0" Length: 36'0" Steel Thickness Per ASME Code Exterior Coating: WHITE PAINT Vessel Includes: Design, Construction, Testing and Labeling in accordance with ASME Code section VIII Division I for a maximum allowable working pressure of 125 psi Vessel straight shell 368" long Vessel head and shell 1/2" thick (2) 2" FITTINGS (1) 6" FLANGE - INLET USE (1) 6" FLANGE - OUTLET USE (5) 12" X 16" ELLIPTICAL MANWAYS (5) INTERMITTENT HALF BAFFLES (2) PERFORATED FULL BAFFLES NAME PLATE *SPOT RADIOGRAPHY	68,594.85	68,594.85
1	INTERNAL POLYURETHANE HIGHDROLINER PLUS CHEMLINE 4200	8,066.79	8,066.79
2	120" UL STYLE SADDLE	1,829.79	3,659.58
2	Seal Weld 120" Saddles to Tank	440.64	881.28
1	URETHANE TOPCOAT - SP-6 BLAST INCLUDED (WHITE)	2,374.92	2,374.92
1	Polyurethane Exterior Touch Up Kit		
	No components or accessories are included unless specifically listed.		

Quote No. 435527 1 Date 4/04/2018
 Quoted by:
 Robert Wallick
 RWallick@HighlandTank.com
 4535 Elizabethtown Rd
 Manheim PA 17545
 PH: 717-664-0600 FAX: 717-664-0617

Prices quoted valid for 20 days.
 Representative:

 DAYBREAK TECHNOLOGIES INC.
 1006 BRIGHTON COURT
 VACAVILLE CA 95687
 Phone: 707-451-9335

Description, prices and conditions accepted. Please return signed copy when placing order.
 Accepted by: _____ Date: ____/____/____
 Per Highland Tank Standard Terms and Conditions: www.HighlandTank.com/Terms/TermsConditions.pdf



Highland Tank & Mfg. Co.

ASME PRESSURE VESSEL QUOTATION

TO: GARBERVILLE SANITATION
 PO BOX 211
 919 REDWOOD DRIVE
 GARBERVILLE CA 95542
 Attention: RALPH EMERSON

Payment Terms: All orders subject to credit approval by Highland Tank.
 25% due at time of order; 65% due prior to shipping;
 10% Net 30, for approved accounts.
 All first-time orders under \$2,000 require payment before delivery.

Estimated Delivery: 13-16 WEEKS
 from date of receipt of approved drawing.

RE: CHLORINE CONTACT

Freight to:

GARBERVILLE CA

QTY	DESCRIPTION	UNIT PRICE	AMOUNT
	Please contact Highland Tank for additional accessories. Quotation based on e-mailed request. Drawings and/or specifications not provided with the request for quotation. *Quote prepared based upon information supplied by customer price may change following further clarification *QUOTE REVISED 3/29/18 PER CUSTOMER REQUEST TO RATE VESSEL FOR 125 PSI, THICKNESS OF STEEL INCREASED TO 1/2" *HIGHLAND TANK WILL STAND BY OUR PRODUCT AND MAKE ALL THE MODIFICATIONS NECESSARY IN THE EVENT THAT THE VESSEL DOES NOT ACHIEVE THE .5 BAFFLE FACTOR. THIS INCLUDES THE COST OF OUR MANUFACTURING/FIELD SERVICE AND OUR ASSOCIATED FREIGHT.		
	Product Subtotal		83,577.42
	FREIGHT		12,962.00
	Net Price (Excluding Taxes)		96,539.42
	Customers should always check with the local authorities having jurisdiction for code compliance.		

Quote No. 435527 1 Date 4/04/2018

Prices quoted valid for 20 days.

Quoted by:
 Robert Wallick
 RWallick@HighlandTank.com
 4535 Elizabethtown Rd
 Manheim PA 17545
 PH: 717-664-0600 FAX: 717-664-0617

Representative:
 DAYBREAK TECHNOLOGIES INC.
 1006 BRIGHTON COURT
 VACAVILLE CA 95687
 Phone: 707-451-9335



Description, prices and conditions accepted. Please return signed copy when placing order.

Accepted by: _____ Date: ____/____/____

Per Highland Tank Standard Terms and Conditions: www.HighlandTank.com/Terms/TermsConditions.pdf

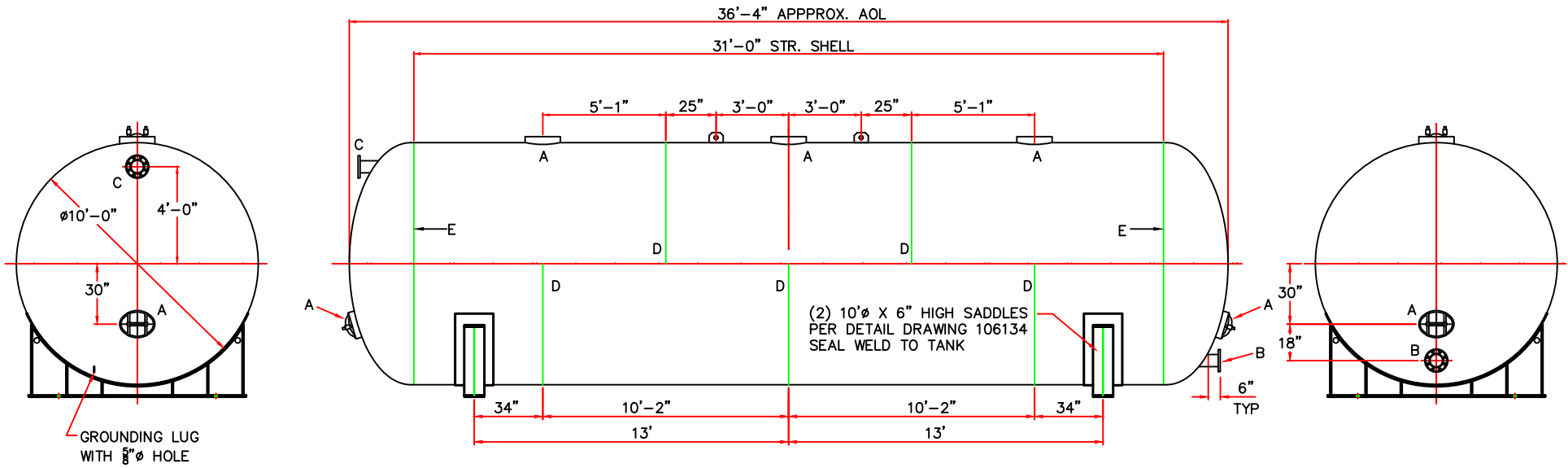

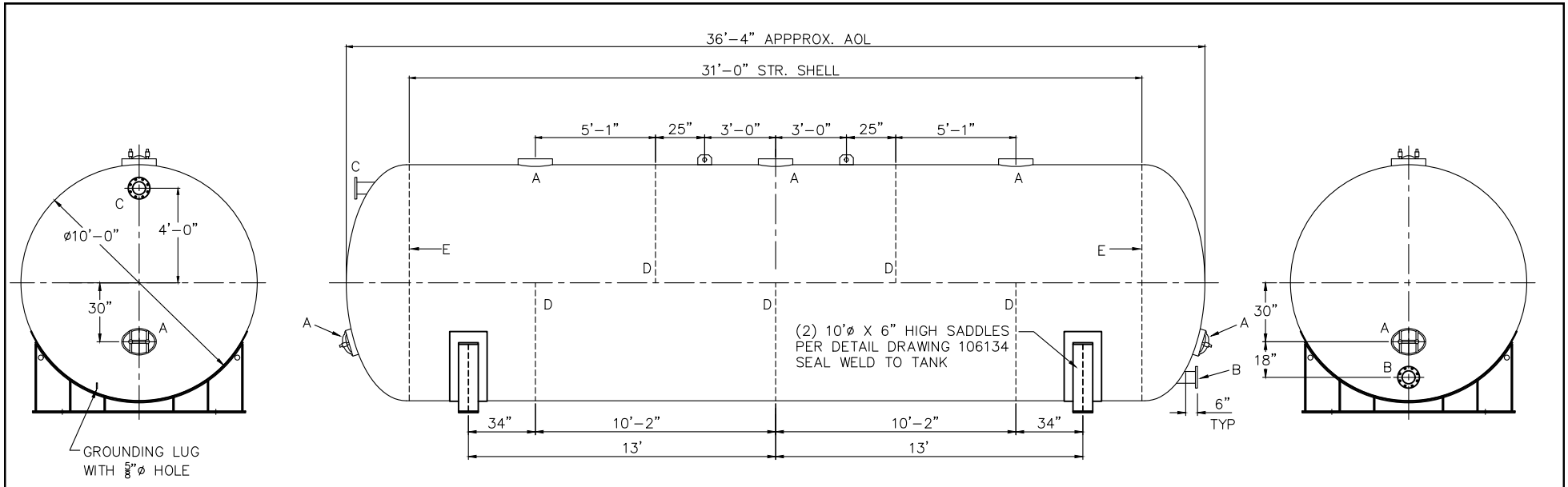

DESIGN DATA	
CAPACITY - 20,000 GALLON	
TYPE - ASME HORIZONTAL PRESSURE VESSEL	
NO. REQ. - 1	
MAX. ALLOW. WORKING PRES. - 125 PSIG @ 140 °F	
MAX ALLOW. EXTERNAL W.P. - - PSIG @ - °F	
MIN. DESIGN METAL TEMP - -20°F @ 125 PSIG	
HYDROSTATIC TEST PRESSURE - 163 PSIG	
CORROSION ALLOWANCE - NONE	
POSTWELD HEAT TREATED - NONE	
RADIOGRAPHY - SPOT RT 3	
HEADS - .425" MIN. 1/2" NOM. SA516 GR 70 ASME 2:1 ELLIPTICAL HEADS	
SHELL - .4626" MIN. 1/2" NOM. SA516 GR 70	
INT. FINISH - SP10 BLAST HIGH DRO-LINER PLUS NSF-61 APPROVED	
EXT. FINISH - SP6 BLAST WHITE URETHANE FINISH	
CONSTRUCTION - BUTT WELD	
ALL TANK FABRICATIONS TO BE IN ACCORDANCE WITH ASME SECTION VIII, DIVISION 1, 2017 EDITION, ALL SHELL, HEAD, FITTINGS, AND MANWAYS TO BE WELDED TO BIGBEE STEEL WELD PROCEDURE PER DRAWING F11151	
HIGHLAND TANK SERIAL #	

NOTE: ALL RIGHTS RESERVED. THIS DRAWING MUST NOT BE REPRODUCED IN ANY FORM WITHOUT THE WRITTEN PERMISSION OF HIGHLAND TANK. HIGHLAND TANK SHALL BE RESPONSIBLE ONLY FOR ITEMS INDICATED ON THIS FABRICATION DRAWING UNLESS OTHERWISE NOTED. CUSTOMER IS RESPONSIBLE FOR VERIFYING CORRECTNESS OF SIZE AND LOCATION OF FITTINGS, ACCESSORIES, AND COATINGS SHOWN ON THIS DRAWING.

TOUCH UP OF FINISHED PAINT IS REQUIRED BY INSTALLATION CONTRACTOR. TOUCH UP PAINT SHIPPED WITH TANK.

LEGEND								
MARK	SIZE	TYPE	RATING	NOZZLE	FLANGE	INTERNAL PROJECTION	RE-PAD (YES/NO)	COMMENTS
A	12" X 16" X 1" X 4"	ELLIPT.	300#	SA106 GR C	-	1-1/8"	NO	w/ NEOPRENE RUBBER GASKET
B	6"	RFSO	150#	SA106 GR B SCH 40	SA105	5/16"	1/2" THK X 2"W SA516 GR 70	
C	6"	RFSO	150#	SA106 GR B SCH 40	SA105	5/16"	1/2" THK X 2"W SA516 GR 70	
D	HALF BAFFLE - 1/4" PLATE							
E	FULL BAFFLE - 1/4" PLATE WITH ROUND PERFORATIONS							

△	MAWP TO 125, THK TO 1/2" NOM.	04/10/18	001
 Highland Tank UNLESS NOTED, TOLERANCES ARE +/- 1"			
20,000 GAL 10'Ø ASME PRESSURE VESSEL			
CUSTOMER: GARBERVILLE SANITATION			
PROJECT: GARBERVILLE CA			
QUOTE NO: 435527		CHK'D BY:	
SCALE: 1/4"=1'-0"	DATE: 03/23/18	DWG. BY: 001	DWG. NO: 106073

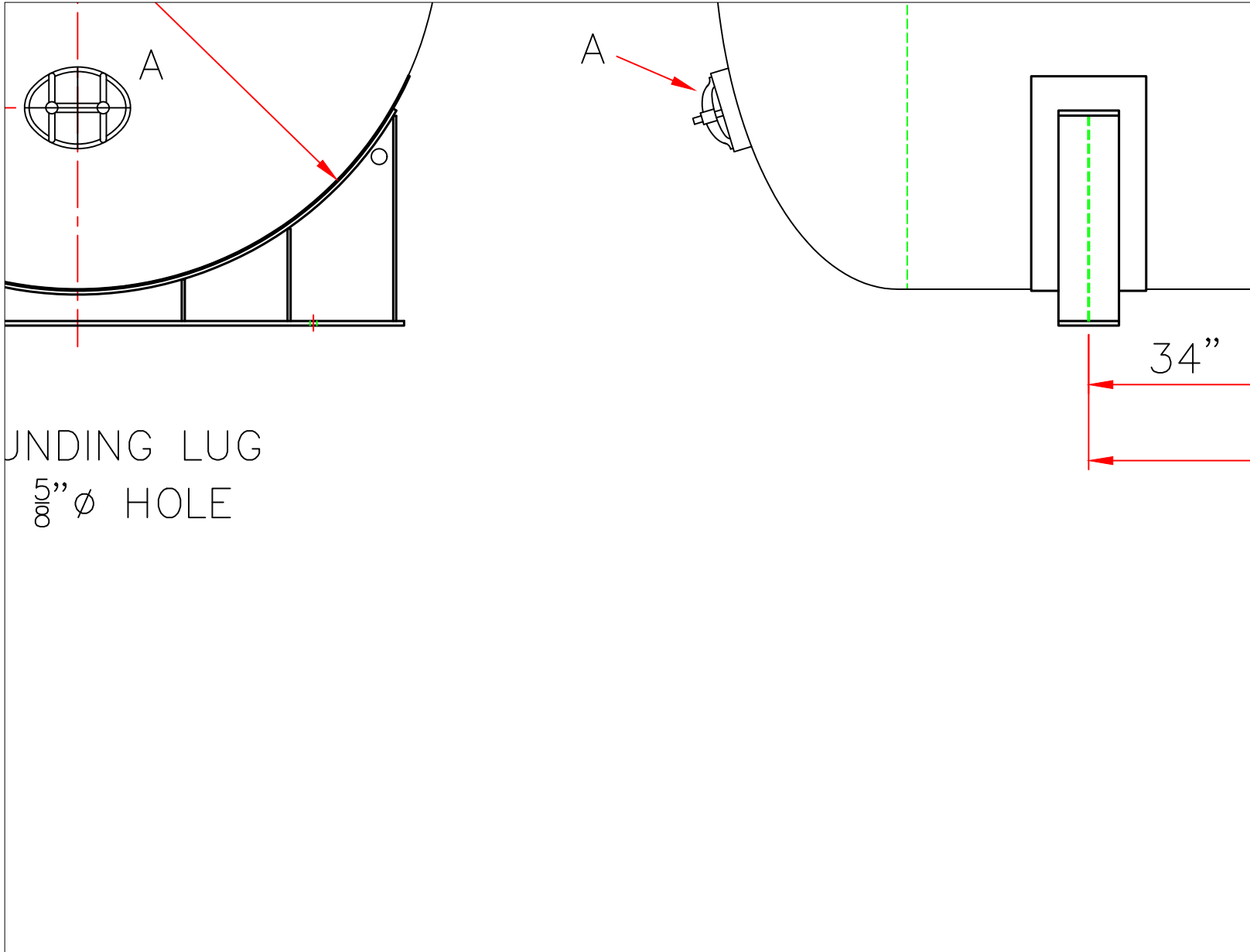



NOTE: ALL RIGHTS RESERVED. THIS DRAWING MUST NOT BE REPRODUCED IN ANY FORM WITHOUT THE WRITTEN PERMISSION OF HIGHLAND TANK®. HIGHLAND TANK® SHALL BE RESPONSIBLE ONLY FOR ITEMS INDICATED ON THIS FABRICATION DRAWING UNLESS OTHERWISE NOTED. CUSTOMER IS RESPONSIBLE FOR VERIFYING CORRECTNESS OF SIZE AND LOCATION OF FITTINGS, ACCESSORIES, AND COATINGS SHOWN ON THIS DRAWING.

TOUCH UP OF FINISHED PAINT IS REQUIRED BY INSTALLATION CONTRACTOR. TOUCH UP PAINT SHIPPED WITH TANK.

NOTE:

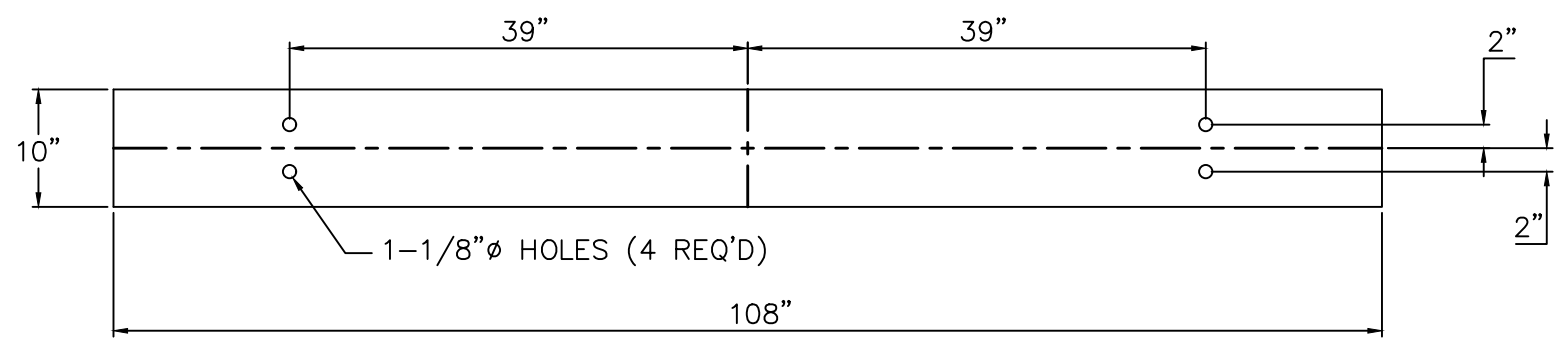
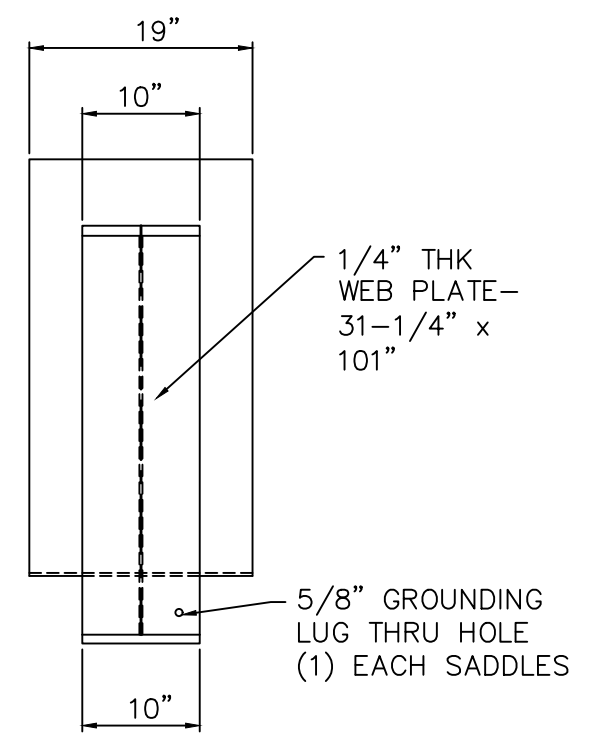
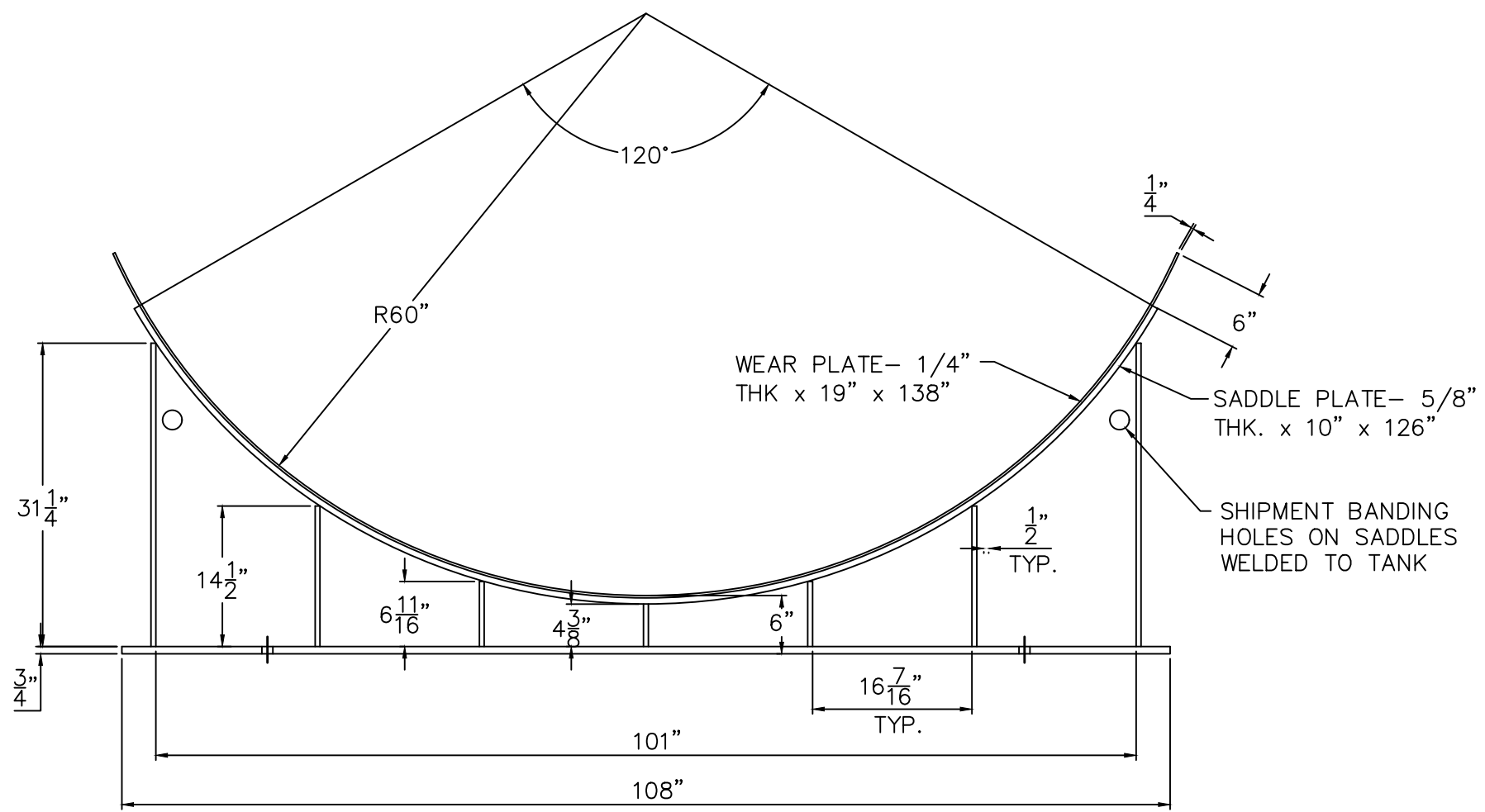
- 1) ANCHOR BOLT HOLE LOCATIONS ARE APPROXIMATE.
- 2) MATERIAL - MILD CARBON STEEL ULN.



1	WEAR PLATE WIDTH TO 19" FROM 18"	04/11/18	001
 Highland Tank UNLESS NOTED, TOLERANCES ARE +/- 1"			
120" Ø SADDLE			
CUSTOMER: GARBERVILLE SANITATION			
PROJECT: GARBERVILLE CA			
QUOTE NO: 435527		CHK'D BY:	
SCALE: 3/4"=1'-0"	DATE: 03/28/18	DWG. BY: 001	DWG. NO: 106134

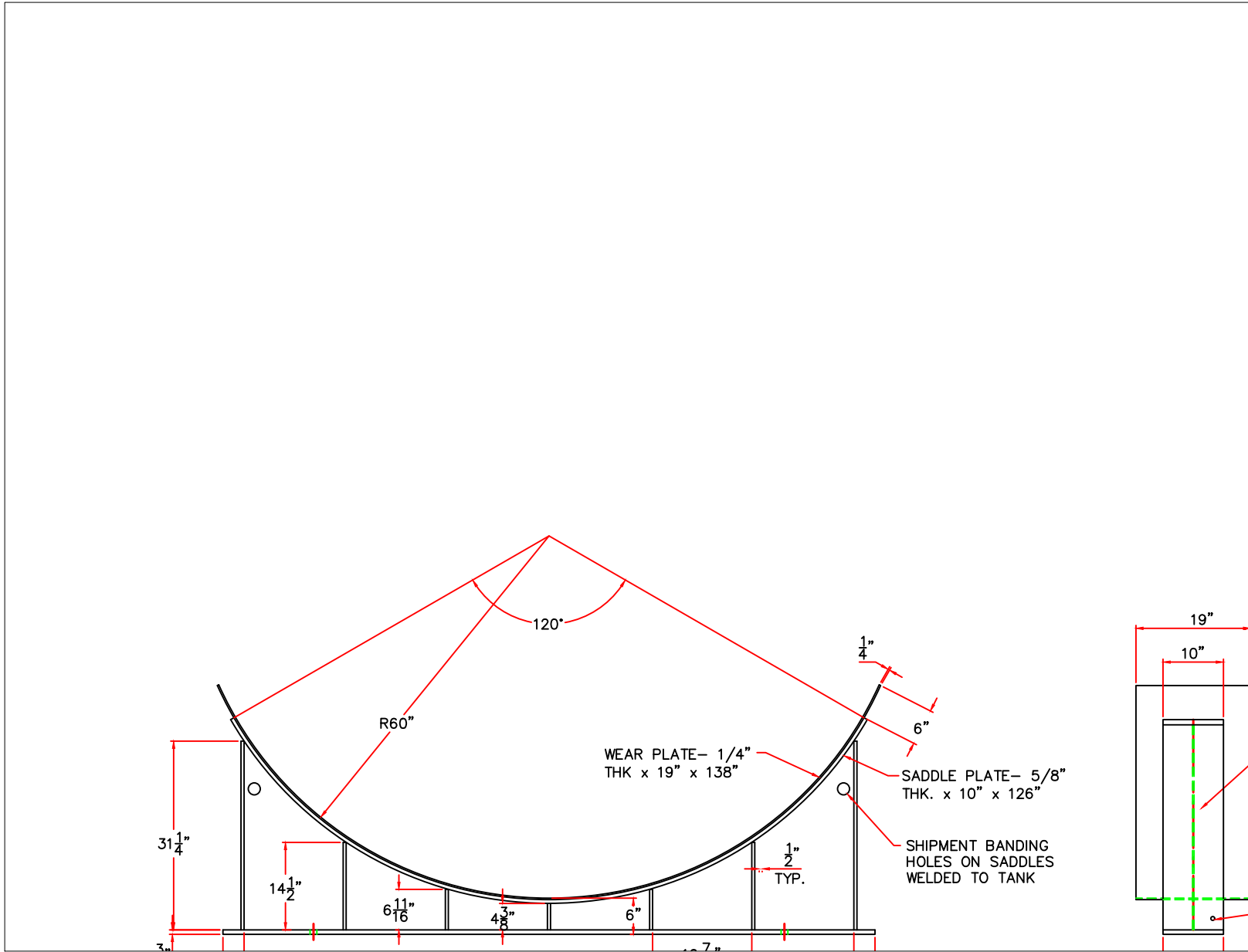

BUDGET COMMITTEE UPDATE

There was a budget committee meeting on April 9th to discuss the 2018-2019 budget and participating with me was Richard, Linda, Jennie Short and Mary. Jennie gave a presentation of the draft budget which her and I worked on and then presented assumptions to consider which included projects, wages and operational expenses.

We discussed the unexpected expenses that impacted the 2017-2018 budget along with how we should plan for similar emergencies with the next budget. We agreed to include between 10-20% increases on Repairs and Maintenance, insurance, Utilities and fuel so that we are prepared for unanticipated problems or increases in services.

We will be making those adjustments and Jennie will be making a budget presentation at the May 22 meeting at which time we will be asking for final approval for the 2018-2019 budget.

We are happy to inform you that amidst the emergencies and unexpected problems last year, we anticipate having a balanced budget for the 2017-2018 year.

Thank You to those who participated in this process

How can RCEA's Public Agency Solar Program Benefit Your Public Agency?

Reduce your **operating costs**
and reduce your **carbon footprint**
by taking advantage of our **NO-COST**
solar energy and energy efficiency
services for your Public Agency



No-cost solar energy and energy efficiency services include:

- Electric load analysis
- No obligation assessment of lighting, refrigeration & other efficiency opportunities for your agency
- Solar site assessments and system design
- Feasibility studies with recommendations, a financial summary and available incentives
- Assistance with identifying funding sources and securing project financing
- Recommendations for available energy savings and efficiency upgrades prior to sizing a solar array for your agency
- Review existing project proposals for energy efficiency measures and solar photovoltaic measures.

Who is eligible?

Participants must be a local public agency or special services district, RCEA member agencies will be given priority, call us to find out more.

*PG&E customers are eligible for RCEA's energy efficiency programs through the public goods charge on transmission and distribution. Please find RCEA's **Nonresidential Application for Energy Services** on our website.

Take the first step:

Fill out the application on reverse side of this flyer and return it to the Redwood Coast Energy Authority. Call us with your questions or to learn more about these no-cost energy efficiency and renewable energy services.

What happens next?

RCEA staff will work with your organization to develop a scope of work and identify feasible and eligible projects. Organizations that decide to move forward with RCEA's recommended energy efficiency or renewable energy measures will enter into a Participation Agreement with RCEA. Project acceptance, implementation, and contracting methods will be developed individually through the Participation Agreement process. Organizations deciding not to upgrade their facility are under no further obligation.

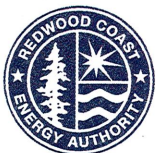

REDWOOD COAST
Energy Authority

mavcollie@redwoodenergy.org
(707) 269-1700 fax:(707) 269-1777
633 3rd St. Eureka, CA 95501
www.RedwoodEnergy.org

Sec 9.7 Customer's Guarantee. The water charge begins when a service connection is installed and the meter is set. The property owner must sign the customer service agreement form prior to being connected. **In which he guarantees payment of future water bills for service required.** This agreement guarantees that the owner is responsible for their property and for all unpaid service charges.

- a. **Renters Customers** are required to place a deposit of **\$100.00 \$200**, refundable **or applied to** account after 2 years of good payment history
- b. Owner **may waive deposit for renter, and** will be responsible for any **unpaid charges**. Account must be current before **tenant's customers's** account can be established.
- c. Failure to receive a bill does not relieve consumer of liability. Any amount due shall be deemed a debt to the District and any person, firm, or corporation failing, neglecting, or refusing to pay said indebtedness shall be liable to an action in the name of the District in any court of competent jurisdiction for the amount.

6/1/2004 adopted



GARBERVILLE SANITARY DISTRICT

P. O. BOX 211 GARBERVILLE CA 95542
PHONE (707) 923-9566 / FAX (707) 923-3130

GSD Account #: _____ **APN#:** _____ **Date:** _____

<u>Customer Information:</u>	
<u>Name:</u>	
<u>Service Address:</u>	
<u>Mailing Address:</u>	
<u>Phone:</u>	<u>Alternative #:</u>
<u>Email:</u>	
<u>Date Moved In:</u>	
<u>Property Owner/Manager Information:</u>	
<u>Name:</u>	
<u>Phone:</u>	<u>Alternative #:</u>
<u>Address:</u>	
<u>Email:</u>	

Deposit \$100.00 (Refundable or applied to account after two years of good payment history)

Cash _____ **Check** _____ **CC** _____

Sec 9.5 Payment of Bills. Bills are due and payable by 4:30 P.M. on the 25th of each month and if not paid a \$5 late charge will be applied

- (a) Customer Bills:
Bills will be mailed by the first of each month.
- (b) Late Payment Procedures:
Bills past due-Courtesy Call
35 days past due-Shut off notice-Hand delivered to service address
7 days after shut off notice is delivered-Water will be turned off. Owner will be notified.
60 days past due – Lien on building/property, - Small claims
120 days past due- Turn over to collection agency
- (c) Adjustments to bills- Payment plans:
The General Manager or designee will be the only person authorized to make adjustments to a bill or enter into a payment plan.
- (d) NSF (non-sufficient funds), from any payment source will require the customer to pay a \$40.00 handling fee.
- (e) Upon 2 NSF (non-sufficient funds), within a 12 month period automatic payment will be denied until an agreement can be reached with the General Manager or designee.

Adopted 02/27/2018

Sec 9.7 Customer's Guarantee. The water charge begins when a service connection is installed and the meter is set. The property owner must sign the customer service agreement form prior to being connected. This agreement guarantees that the owner is responsible for their property and for all unpaid service charges.

- a. Customers are required to place a deposit of \$100.00. Refundable or applied to account after 2 years of good payment history
- b. Owner will be responsible for any unpaid charges. Account must be current before customer's account can be established.
- c. Failure to receive a bill does not relieve consumer of liability. Any amount due shall be deemed a debt to the District and any person, firm, or corporation failing, neglecting, or refusing to pay said indebtedness shall be liable to an action in the name of the District in any court of competent jurisdiction for the amount.

Adopted 6/1/2004

Customer Signature: _____ **Date** _____

Owner/Manager Signature: _____ **Date** _____

General Manager Signature: _____ **Date** _____

RESOLUTION 18-003
THIS RESOLUTION AUTHORIZES THE GARBERVILLE SANITARY
DISTRICT TO CHANGE WATER ORDINANCE,
SEC. 9.7 PAYMENT GUARANTEE DEPOSIT

A. WHEREAS, It has been determined that the Garberville Sanitary District will change Water Ordinance Sec. 9.7 Customer Guarantee.

B. WHEREAS, Resolution 18-003 will allow the Board to make appropriate changes to this Ordinance and give clear direction to customers, what the procedures are and what the deposit will be for new service or change of customer service.

C. WHEREAS, This Resolution will explain each step of the change of customer/owner responsibilities along with the requirements of Garberville Sanitary District.

D. WHEREAS, The adaption of Resolution 18-003 will take effect immediately and will describe the Customer Guarantee Deposit along with the owner responsibilities for their tenant.

E. WHEREAS, The new Water Ordinance, Sec. 9.7, Customer's Guarantee, will replace the existing ordinance.

WATER ORDINANCE, SECTION 9.7 CUSTOMERS GUARANTEE

Sec 9.7 Customer's Guarantee. The water charge begins when a service connection is installed and the meter is set. The property owner must sign the customer service agreement form prior to being connected. This agreement guarantees that the owner is responsible for their property and for all unpaid service charges.

- a. Customers are required to place a deposit of \$100, refundable

- or applied to account after 2 years of good payment history
- b. Owner will be responsible for any unpaid charges. Account must be current before customer's account can be established.
 - c. Failure to receive a bill does not relieve consumer of liability. Any amount due shall be deemed a debt to the District and any person, firm, or corporation failing, neglecting, or refusing to pay said indebtedness shall be liable to an action in the name of the District in any court of competent jurisdiction for the amount.

NOW, THEREFORE LET IT BE KNOWN THAT, THE BOARD OF DIRECTORS OF THE GARBERVILLE SANITARY DISTRICT APPROVES CHANGING THE WATER ORDINANCE, SEC. 9.7, CUSTOMER'S GUARANTEE.

RESOLUTION 18-003 WAS PASSED, APPROVED AND ADOPTED THIS 24th DAY OF APRIL 2018 BY THE FOLLOWING ROLL CALL VOTE:

AYES:

NOES:

ABSTAIN:

ABSENT:

Linda Broderson, Board President

ATTEST:

Ralph Emerson, General Manager

PERSONNEL POLICY

INTRODUCTION

Welcome to the Garberville Sanitary District. The District was organized April 12, 1932, as a Special District to provide services to our community. The District is an independent special district governed by a five member Board of Directors elected by Garberville's voters.

The Garberville Sanitary District is committed to a standard of excellence in the services that it provides to its customers. GSD employees participate in efforts to meet this commitment to achieve a high level of service to the community.

Each employee is expected to uphold the GSD commitment to "professionalism" which is understood to be an integral part of each employee's position responsibilities. "Professionalism" includes, but is not limited to, sharing expertise and assistance with other staff, working as a team player, maintaining a positive attitude, pitching in at time of crises, and providing customers, community, GSD Board Members and other GSD staff with the highest quality service and respect.

This Employee Policy is intended to help you get acquainted with the Garberville Sanitary District (GSD). It explains some of our philosophies and beliefs, and describes, in general terms, some of our employment guidelines. We hope that it will serve as a useful reference document throughout your employment at GSD. This policy supersedes and replaces all previous personnel policies and guidelines. To determine if this version of the policy is current, you are requested to contact the GSD office.

GARBERVILLE SANITARY DISTRICT

PERSONNEL POLICY

1.0 EMPLOYMENT AT WILL

Garberville Sanitary District is an “at-will” employer. GSD and GSD employees have the right to terminate the employment relationship at any time, with a minimum of two weeks written advance notice of the termination date, with or without cause. There are no express or limited covenants and no statements in this manual that shall in any way conflict with this mutual right and obligation. This type of employment is intended to be employment “at will” under California law. No one other than the Board of Directors has the authority to alter this arrangement, to enter into an agreement for employment for a specific period of time, or to make any agreement contrary to this “at will” policy. Any agreement that in any way alters the “at will” status of an employee must be authorized by a specific Resolution of the Board of Directors.

2.0 ORGANIZATION

2.1 Chain of Command

The chain of command is shown in the diagram in Appendix “A.” The **District Administrator General Manager** will be **the Chief Executive Officer** responsible for all day-to-day operations **function**. If the **District Administrator General Manager** is not available then the Board Chair will be consulted and if the Board chair is not available, next in line is the Vice Chair, and then decision making authority extends to any Board Member that is available.

2.2 Absence of **District Administrator General Manager**

When the **District Administrator General Manager** is absent, or otherwise not available, his/her staff will report to the Board Chair, as per chain of command in all matters requiring a managerial decision, or as specified by their manager before his/her absence.

3.0 EMPLOYMENT PROCESS

3.1 Equal Opportunity

The Garberville Sanitary District will recruit, hire, train, promote and administer human resource activities without regard to age, sex, race, creed, color or national origin, or any other legally protected status, and shall comply with the intent and the letter of all applicable laws which prohibit discrimination and affirm equal opportunity.

GARBERVILLE SANITARY DISTRICT ORGANIZATIONAL CHART APRIL 24TH 2017

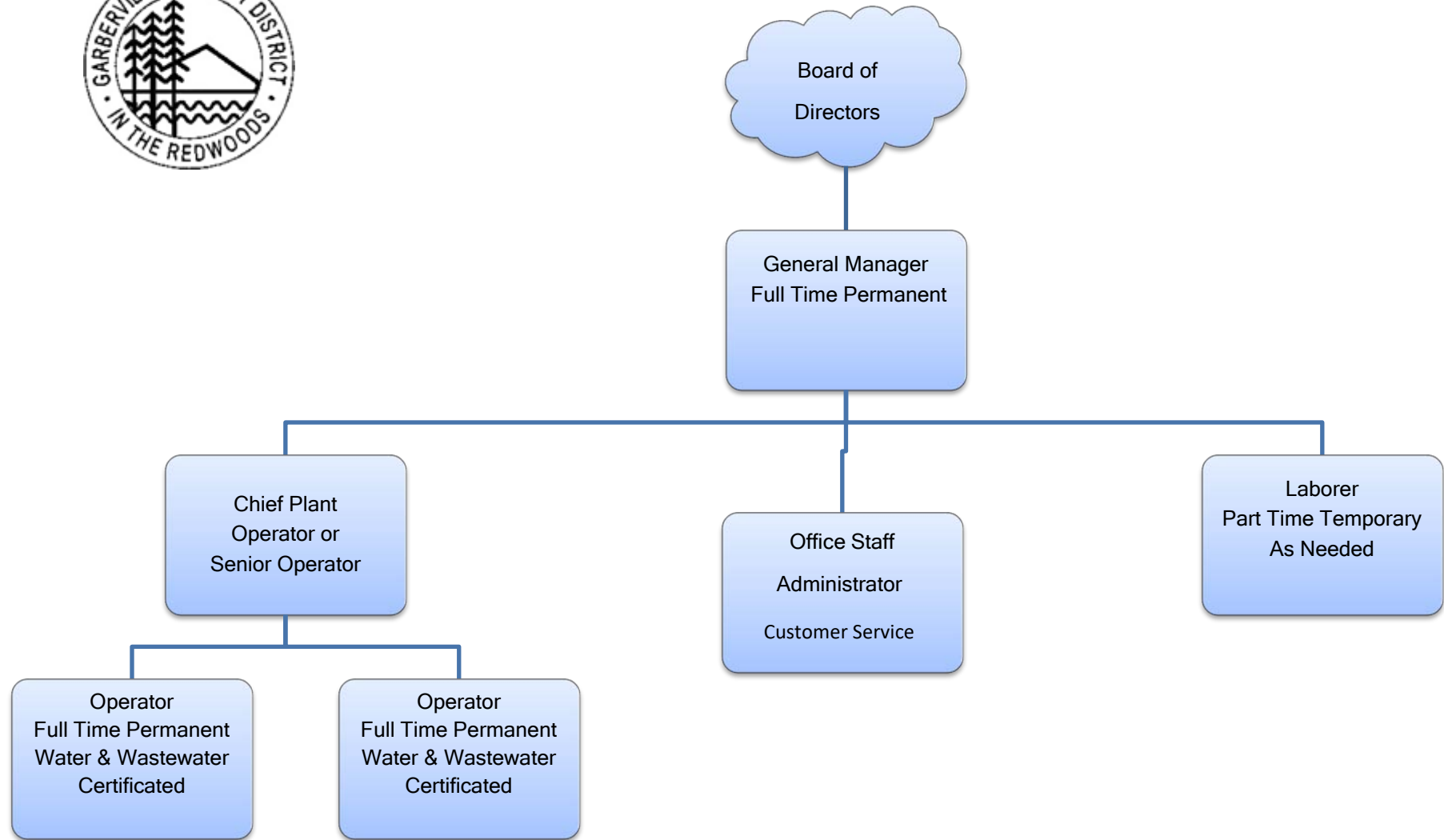



GARBERVILLE SANITARY DISTRICT

P.O. BOX 211 • GARBERVILLE, CA 95542 • (707) 923-9566

RESOLUTION NO. 18-007

ESTABLISHING UPDATED SIGNING AUTHORIZATIONS FOR THE DISTRICT'S RESERVE ACCOUNTS 1030 AND 1031 HELD WITH THE COUNTY OF HUMBOLDT

WHEREAS, the Board of Directors of the Garberville Sanitary District, (the District) has determined it to be in the best interest of the District to establish updated authorizations for its reserve accounts 1030 and 1031 at County of Humboldt (the Treasury); and

WHEREAS, the District has two reserve accounts - account 1031 for water and 1030 for sewer.

NOW, THEREFORE, BE IT RESOLVED AND ORDERED, that all requests for transfers or issuance of checks from these accounts for Chlorine Contact Chamber replacement expenses between \$0 and \$100,000 must be signed by the General Manager and a Board Member, and all transfers or issuance of checks in amounts over \$100,001, will require board action; and

BE IT FURTHER RESOLVED AND ORDERED, that upon completion of this chlorine contact chamber replacement project, this resolution will be rescinded: and

BE IT FURTHER RESOLVED AND ORDERED, that the District's Administrative Assistant or Business Manager will not have the authority to make any requests for checks or transfers and will be responsible for reconciling all accounts; and

BE IT FURTHER RESOLVED AND ORDERED, that Linda Brodersen, Chairperson of this District is hereby authorized and empowered to certify and to execute any written authorizations as needed or required by the Treasury to implement these protocols.

Passed and adopted by the Garberville Sanitary District's Board of Directors on April 24th, 2018 during a regular business meeting, by the following vote:

AYES: Directors _____

NOES: Directors _____

EXCUSED: Directors _____

_____, Chairperson

ATTEST: Linda Brodersen

Ralph Emerson
Clerk of Board of Directors